

HEAVY VEHICLE LOCAL ROAD REPORT

Sydney Metro West – Western Tunnelling Package



Clyde/ Rosehill

ISSUE DATE: 9 JUNE 2022

Document Details

Document Title	Clyde/ Rosehill Heavy Vehicle Local Road Report
Project Name	Sydney Metro West – Western Tunnelling Package
Client	Sydney Metro
Document Reference No.	SMWSTWTP-GLO-CLJ-HS-RPT-000001-D.01
Revision Date	7 June 2022

Document Authorisation

Action Type	Position	Name	Signature	Date Signed
Prepared by	Traffic Manager	S Lewis		7 June 2022
Reviewed by	Construction Manager	John Gadallah		7 June 2022
<p>I hereby confirm this activity and all associated work, have been appropriately planned and the relevant resources are available to conduct the work in accordance with the agreed method.</p> <p>I hereby approve this activity to commence, as the stated controls applications are the most appropriate and are in accordance with the Risk Matrix.</p>				
Approved by	Deputy Project Director	S Hussey		7 June 2022

NOTES:

Once all signatures have been obtained, the Document Author is responsible for ensuring the signed and approved hard and soft copies are uploaded on to the project share drive or passed to the Responsible Person for filing.

TABLE OF CONTENTS

Document Details.....	2
Document Authorisation.....	2
Definitions/ Abbreviations	5
1 EXECUTIVE SUMMARY	7
2 INTRODUCTION	8
2.1 Purpose.....	9
2.2 Planning approval	9
3 COMPLIANCE.....	10
3.1 Ministerial Conditions of Approval.....	10
3.2 Revised Environmental Management Measures	11
4 LEGAL AND OTHER REQUIREMENTS	12
4.1 Relevant Legislation.....	12
4.2 References and guidelines	12
5 THE EXISTING ENVIRONMENT	13
5.1 Locality and land use	13
5.2 Wentworth Street	18
5.3 Kay Street	20
5.4 Unwin Street	20
5.5 Shirley Street	21
5.6 Martha Street	21
5.7 Deniehy Street	22
5.8 Tennyson Street.....	22
6 SITE OPERATIONS	23
6.1.1 Impact on traffic flow	23
6.1.2 Impact on parking	23
6.1.3 Impact on active transport users.....	23
6.1.4 Managing cumulative impacts.....	24
7 FLEET MANAGEMENT	26
7.1 Road dilapidation report.....	26
7.2 Drivers and operators	27
7.3 Proposed vehicle movements.....	27
7.4 EIS routes for Heavy Vehicles	28
7.5 Proposed heavy vehicle routes.....	29
7.6 Fleet safety	29
8 COMMUNITY AND CONSULTATION	32
8.1 Stakeholders	32
8.2 Workforce communications.....	32

List of tables

Table 1: Ministerial Conditions of Approval.....	10
Table 2: Heavy Vehicle movements per hour per phase of works.....	28
Table 3: Roads to be used by Heavy Vehicles	29
Table 4: Heavy vehicle requirements.....	29
Table 5: Stakeholder consultation.....	32
Table 6: Swept path drawing and suitability.....	34

List of figures

Figure 3-1: Project location	8
Figure 6-1: Site locality	14
Figure 6-2: Existing land use zoning.....	15
Figure 6-3: Sensitive receivers locations	16
Figure 6-4: NSW Road Classification Map (source: TfNSW Road Network Classification Map	17
Figure 6-5: PBS Routes (source: TfNSW PBS Network map).....	18
Figure 6-6: Existing shared path (source: TfNSW Cycleway finder).....	20
Figure 6-7: Speed management device on Unwin Street	21
Figure 7-1: EIS Heavy Vehicle moments (source: Chapter 10 EIS)	27
Figure 7-2: EIS nominated heavy vehicle routes	28
Figure 7-3: Shared path warning sign and truck decals.....	23
Figure 7-4: Sign and decal locations.....	24
Figure 9-1: Swept path analysis locations	33

List of appendices

A: : Swept path analysis.....	33
B: : Written confirmation.....	35
C: : Stakeholder consultation.....	36
D: : Road Dilapidation Report Transmittal.....	37

Definitions/ Abbreviations

Acronym	Definition
BNS	Burwood North Station (not applicable to WTP works)
CPC	City of Parramatta Council
CEMP	Construction Environmental Management Plan
CJP	Customer Journey Planning (formerly SCO/ TC)
CLY	Clyde site
CMSF	Clyde Main Stabling Facility
CTMF	Construction Traffic Management Framework
CTMP	Construction Traffic Management Plan
CC	Cumberland Council
DMS	Delivery Management System
DPE	Department of Planning and Environment
EIS	Environmental Impact Statement
EPA	Environmental Protection Agency
EPL	Environment Protection License
FDS	Five Dock Station (not applicable to WTP works)
GLC	Gamuda and Laing O'Rourke Consortium
HVLR	Heavy Vehicle Local Road report
LTC	Local Traffic Committee (Council)
MCoA	Ministerial Conditions of Approval
NSMS	North Strathfield Metro Station (not applicable to WTP works)
PMS	Parramatta Metro Station
RMS	Roads and Maritime Service (now part of TfNSW)
ROL	Road Occupancy License
ROP	Road Opening Permit
SCO	Sydney Coordination Office (now known as CJP)
SMW	Sydney Metro West
SOPMS	Sydney Olympic Park Metro Station
SZA	Speed Zone Authorisation
TBM	Tunnel Boring Machine
TBS	The Bays Station (not applicable to WTP works)
TC	Transport Coordination (formerly SCO now known as CJP)
TCG	Traffic Control Group
TCP	Traffic Control Plan (now known as TGS)

Acronym	Definition
TfNSW	Transport for New South Wales
TGS	Traffic Guidance Scheme (formerly TCP)
TMC	Transport Management Centre
TTLG	Traffic and Transport Liaison Group
REMM	Revised Environmental Management Measure
WMS	Westmead Metro Station

1 EXECUTIVE SUMMARY

This Heavy Vehicle Local Road report (HVLR) has been developed to address the requirements of the Ministerial Conditions of Approval related to the Critical State Significant Infrastructure #10038 Stage 1 of the Sydney Metro West project.

The HVLR identifies the heavy vehicle routes into the sites not identified in the Environmental Impact Statement, the road classification and the suitability of the routes based on swept path analysis and adjacent land uses.

For the Clyde/ Rosehill sites, the routes proposed into site for the works are via Wentworth Street, Kay Street, Unwin Street, Shirley Street, Martha Street, Deniehy Street and Tennyson Street, the latter two roads will be subsumed within the construction site as will Wentworth Street north of Kay Street. The routes other than Martha Street between Wentworth Street and Deniehy Street, Deniehy Street (entire length) and Tennyson Street (entire length) also form part of the Performance Based Standard (PBS) routes as identified on the TfNSW website.

The suitability of the routes has been assessed based on typical Heavy Vehicle sizes eg: semi-trailers and truck and dog combinations. The swept paths show that all vehicle types, other than semi-trailer access from Unwin Street into Shirley Street and Martha Street onto Wentworth Street, operate satisfactorily, based on this finding, the use of semi-trailers will not be pursued. Semi-trailer access can be provided via the other local streets assessed in this report.

Wentworth Street crosses Martha Street where the M4 Motorway shared path cycleway route is located. Similarly, Martha Street crosses the shared path crossing at the eastern end of Martha Street/ Deniehy Street. Signs have previously been installed to highlight the shared path crossing on Wentworth Street and on the shared path itself. Further signs are proposed to be installed on Martha Street and Deniehy Street. The placement of decals on the shared path on its approach to Martha Street is also proposed to highlight the existence of the shared path to motorists and the presence of trucks to shared path users.

2 INTRODUCTION

Sydney Metro West (SMW) is a new underground railway connecting Greater Parramatta and the Sydney CBD. It will provide fast connections between greater Sydney's two major business centres as well as providing better access to the growing business and entertainment precincts in Olympic Park and Pyrmont, the health and medical research hub at Westmead and the future business and tourism site at The Bays.

SMW is being delivered in several packages. The Western Tunnelling Package WTP is an one package for SMW. It involves 9km of twin railway tunnels between Sydney Olympic Park and Westmead as well as:

- Westmead Station box excavation, including temporary support, stub tunnels, partially mined station cavern and crossover cavern including permanent lining and support
- Parramatta Station, including excavation of station box and associated support
- Clyde Stabling and Maintenance Facility (SMF), including permanent dive structure, portal, spur running tunnels, spur tunnel junction cavern, bulk earthworks, civil structures, utilities corridor, road crossing and creek diversion
- Rosehill Services Facility, including shaft excavation, permanent lining, and lateral support
- a precast segment manufacturing facility at Eastern Creek
- demolition and site clearance work.

The entire Sydney Metro West Stage 1 is shown in Figure 2-1 below. The WTP Project location is from Westmead to Sydney Olympic Park.

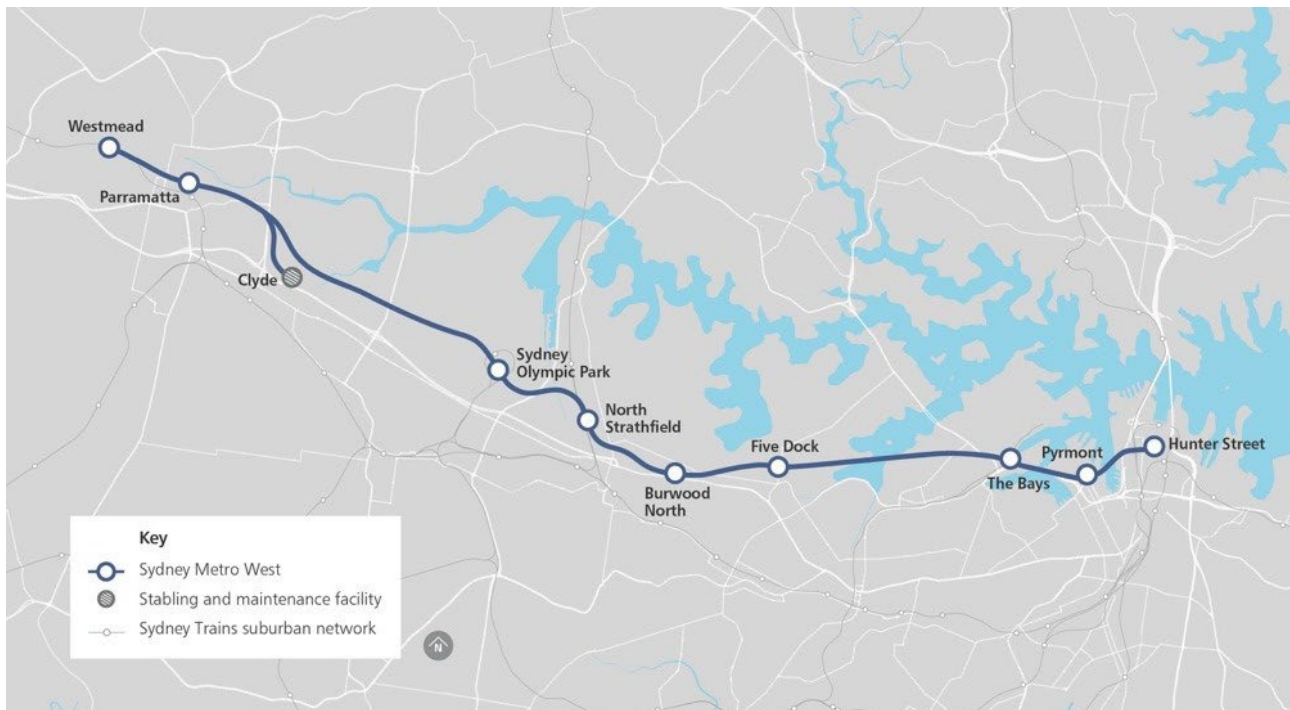

Figure 2-1: Project location

2.1 Purpose

This heavy vehicle Local Road (HVLR) report details the heavy vehicle routes as noted in the Environmental Impact Statement for the project and the proposed routes to be used for the Clyde/ Rosehill site access/ egress.

This report is a sub-plan to the site specific Construction Traffic Management Plan for the Clyde/ Rosehill work sites and has been prepared in accordance with Gamuda Australia and Laing O'Rourke Consortium (GLC) legal, planning and contractual requirements and environmental management system (EMS) including compliance to the Ministerial Conditions of Approval (MCoA), Revised Environmental Management Measures (REMM) and the Construction Traffic Management Framework

This report enables the project to manage potential construction traffic impacts systematically and is applicable to the Clyde site and all project activities.

2.2 Planning approval

Sydney Metro West – Westmead to The Bays Concept and Stage 1 was subject to environmental impact assessment under the NSW Environmental Planning and Assessment Act, 1979 (EP&A Act). It was declared a Critical Stage Significant Infrastructure (CSSI) by the Minister for Planning and Public Spaces.

An Environmental Impact Statement (EIS) was prepared under Division 5.2 of the EP&A Act and in accordance with Part 3 of Schedule 2 of the Environmental Planning and Assessment Regulation, 2000. Following exhibition of the EIS, an Amendment Report and Submissions Report was also prepared, after which the Minister carried out an assessment and made a determination.

The planning approval (Infrastructure Approval SSI 100038) and related environmental assessment documents are located at [Sydney Metro West - Concept and Stage 1 \(major civil construction between Westmead and The Bays\) | Planning Portal - Department of Planning and Environment \(nsw.gov.au\)](#)

3 COMPLIANCE

3.1 Ministerial Conditions of Approval

The Ministerial Conditions of Approval are listed below in Table 1.

Table 1: Ministerial Conditions of Approval

MCoA	Condition requirement	Document reference
A47	All heavy vehicles used for spoil haulage must be clearly marked on the sides and rear with the project name and application numbers to enable immediate identification by a person viewing the heavy vehicle standing 20m away	Table 4
D86	Local roads proposed to be used by Heavy Vehicles to directly access construction sites that are not identified in the documents listed in Condition A1 of this schedule must be approved by the Planning Secretary and be included in the CTMPs	This report
D87	All requests to the Planning Secretary for approval to use local roads under Condition D86 above must the following a) A swept path analysis	Appendix A
D87	All requests to the Planning Secretary for approval to use local roads under Condition D86 above must the following b) Demonstration that the use of local roads by Heavy vehicles for the CSSI will not compromise the safety of pedestrians and cyclists of the safety of two way traffic flow on two way roadways	This report
D87	All requests to the Planning Secretary for approval to use local roads under Condition D86 above must the following c) Details as to the date of completion of the road dilapidation surveys for the subject local road and	Appendix D
D87	All requests to the Planning Secretary for approval to use local roads under Condition D86 above must the following d) Measures that will be implemented to avoid where practicable the use of local roads past schools, aged care facilities and child care facilities during their peak operation times and	This report
D87	All requests to the Planning Secretary for approval to use local roads under Condition D86 above must the following e) Written advice from an appropriately qualified professional on the suitability of the proposed Heavy Vehicle route which takes into consideration items a) to d) of this condition	Appendix B
D88	Before any local road is used by a Heavy Vehicle for the purposes of construction of Stage 1 of the CSSI, a Road Dilapidation Report must be prepared for the road. A copy of the Road Dilapidation Report must be provided to the Relevant Road Authority(s) within three (3) weeks of completion of the survey and at no later than one (1) month before the road being used by Heavy Vehicles associated with the construction of Stage 1 of the CSSI	Section 7.1 and Appendix D

MCoA	Condition requirement	Document reference
D89	If damage to roads occurs because of the construction of Stage 1 of the CSSI, the Proponent must either (at the Relevant Road Authority's discretion) a) Compensate the Relevant Road Authority for the damage so caused or b) Rectify the damage to restore the road to at least the condition it was in pre-work as identified in the Road Dilapidation Report	Section 7.1
D90	Vehicles associated with the project workforce (including light vehicles and Heavy Vehicles must be managed to: a) Minimise parking on public roads	Section 6.1.2
	Heavy Vehicles must be managed to: b) Minimise idling and queuing on state and regional roads	Section 7
	Heavy Vehicles must be managed to: c) Not carry out marshalling of construction vehicles near sensitive land user(s)	Section 7
	Heavy Vehicles must be managed to: d) Not block or disrupt access across pedestrian or shared user paths at any time unless alternate access is provided and	Section 6.1.3
	Heavy Vehicles must be managed to" e) Ensure spoil haulage vehicles adhere to the nominated haulage routes identified in the CTMPs	Section 7

3.2 Revised Environmental Management Measures

The Revised Environmental Management Measures are listed below in Table 2

Table 2: Revised Environmental Management Measures

REMM#	Condition requirement	Site(s)	Document Reference
TT6	All trucks would enter and exit construction sites in a forward direction, where feasible and reasonable	All	Section 6.1.1
TT7	Construction site traffic would be managed to minimise movements during peak periods	All	Section 6.1.1
TT8	Construction site traffic immediately around construction sites would be managed to minimise vehicle movements through school zones during pick up and drop off times	WMS PMS BNS FDS	Not applicable to Clyde/ Rosehill site

4 LEGAL AND OTHER REQUIREMENTS

4.1 Relevant Legislation

Identified regulatory requirements are:

- An approved and valid Road Occupancy Licence (ROL)
- An approved relevant Speed Zone Authorisation (SZA)
- Australian Road Rules form the basis for state and territory road rules
- *Roads Act, 1993* (NSW) sets out rights along a public road, establishes procedures for a public road and provides the classifications of roads
- *Heavy Vehicle National Act 2013 and Regulation, 2013* (NSW)
- *Heavy Vehicle (Adoption of National Law) Act, 2013* (NSW)
- *Dangerous Goods (Road and Rail Transport) Act, 2008*
- Road and Rail Transport (Dangerous Goods) (Road) Regulation, 1998
- Australian Code for the Transport of Dangerous Goods by Road and Rail (National Transport Commission, 2008)
- Dangerous Goods (Road and Rail Transport) Regulation, 2014
- Australia Code for the Transport of Dangerous Goods by Road and Rail Edition 7.7 (National Transport Commission, 2020)
- *Environmental Planning and Assessment Act, 1979* – under which the project approval was granted including the Environmental Impact Statement and Construction Traffic Management Framework

4.2 References and guidelines

The relevant standards, codes and guidelines are noted below:

- AustRoads Cycling Aspects of AustRoads Guides, 2017
- AustRoads Guide to Traffic Management, 2020 – Parts 1-13
- AustRoads Guide to Road Design, 2013 to 2021-Parts 1-7
- AustRoads Guide to Road Safety, 2019 to 2021 – Parts 1-7
- Roads and Traffic Authority, NSW Guide to Traffic Generating Developments, 2002 and further updates as provided
- Roads and Traffic Authority, NSW Bicycle Guidelines, version 1.2, 2005
- Roads and Maritime QA Specification G10, Traffic Management, 2020
- Roads and Maritime NSW Speed Zoning Guidelines, 2011
- TfNSW Traffic Control at Worksites Manual, version 6.1, 2022 and
- TfNSW NSW Substantiable Design Guidelines, version 4, 2017

5 THE EXISTING ENVIRONMENT

5.1 Locality and land use

The site is located in an industrial are of Western Sydney and is bounded by the M4 Motorway to the south, James Ruse Drive to the west, Unwin Street to the north and Shirley Street to the east as shown on Figure 5-1

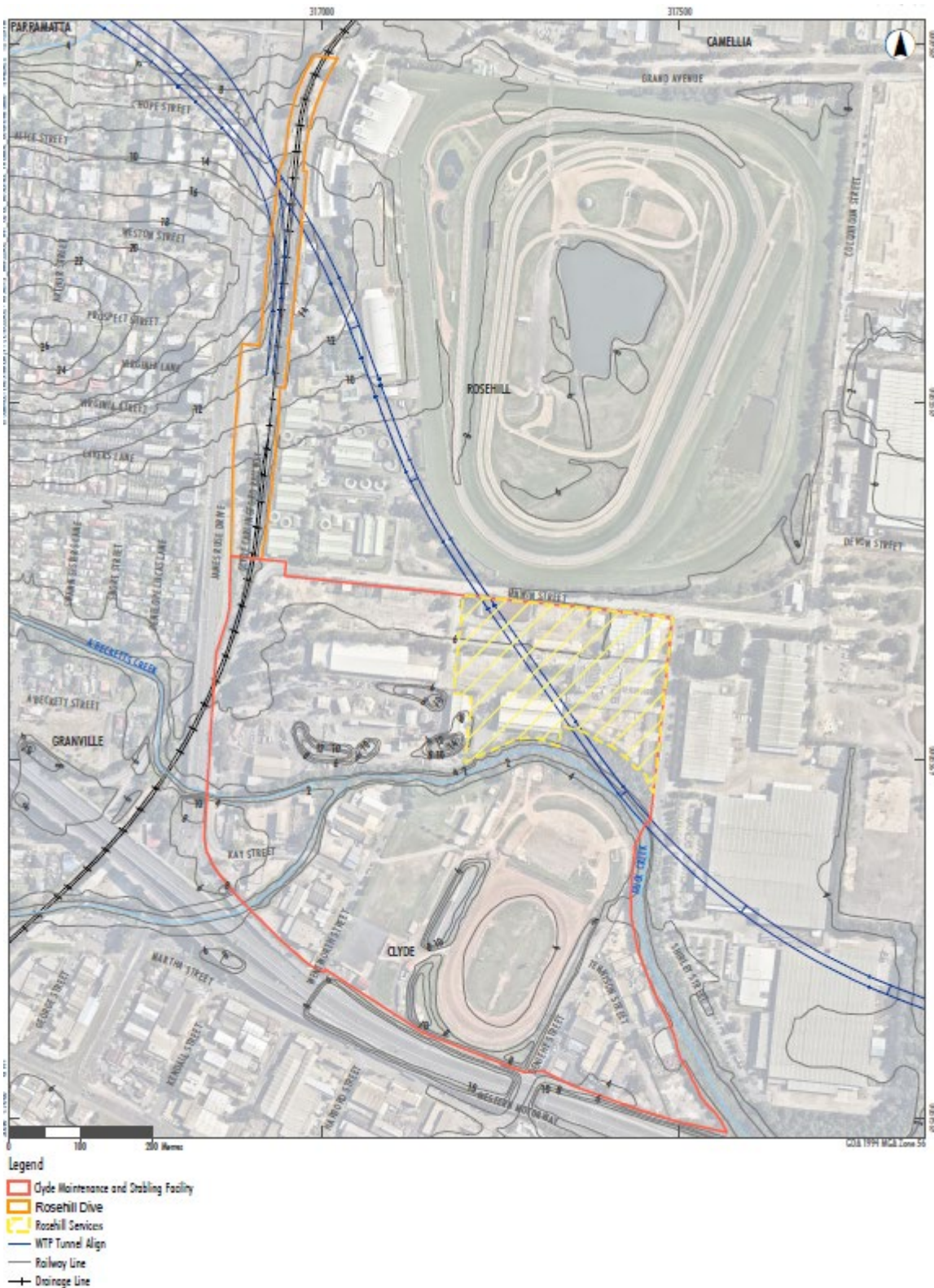

Figure 5-1: Site locality

The site is located in a highly industrialised area is predominantly zoned industrial uses with recreational uses to the north (Rosehill Gardens Racecourse) and the old Sydney Speedway, which has now been closed. No educational, childcare or community use facilities are provided near the construction site, refer to Figure 5-2.

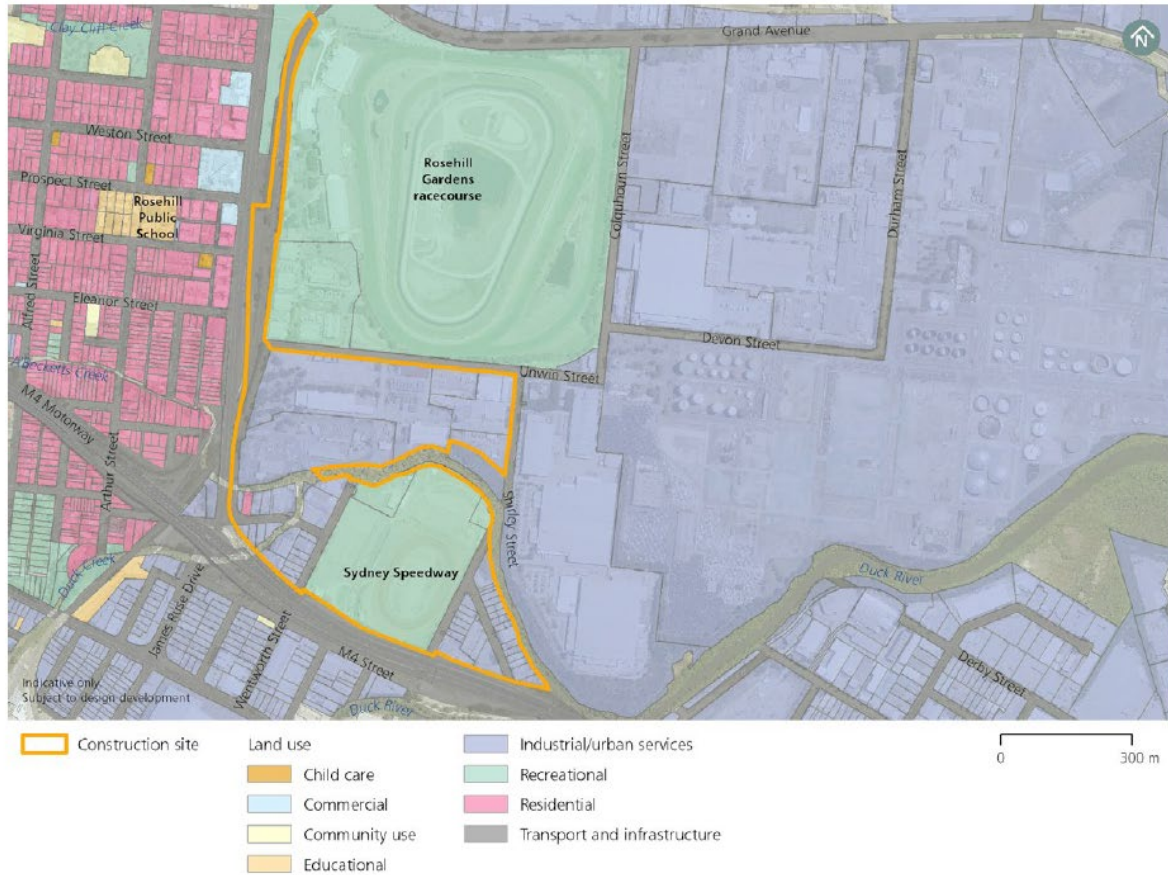

Figure 5-2: Existing land use zoning

A review of the existing sensitive receivers and their locations was undertaken by Sydney Metro during the EIS development phase. The results of this review is provided on Figure 5-3. It is noted that no aged care or child care facilities are located near the Clyde Rosehill sites. Child care facilities are located to the west of James Ruse Drive, an arterial road.

A land use survey is included as part of the detailed Noise and Vibration Impact Statement (SMWSTWTP-GLO-1NL-NL000-NV-PLN-000002). This is currently in draft and is being informed by construction from the EPA and other stakeholders. Throughout the construction period this detailed Noise and Vibration Impact Statement will be an evolving document.

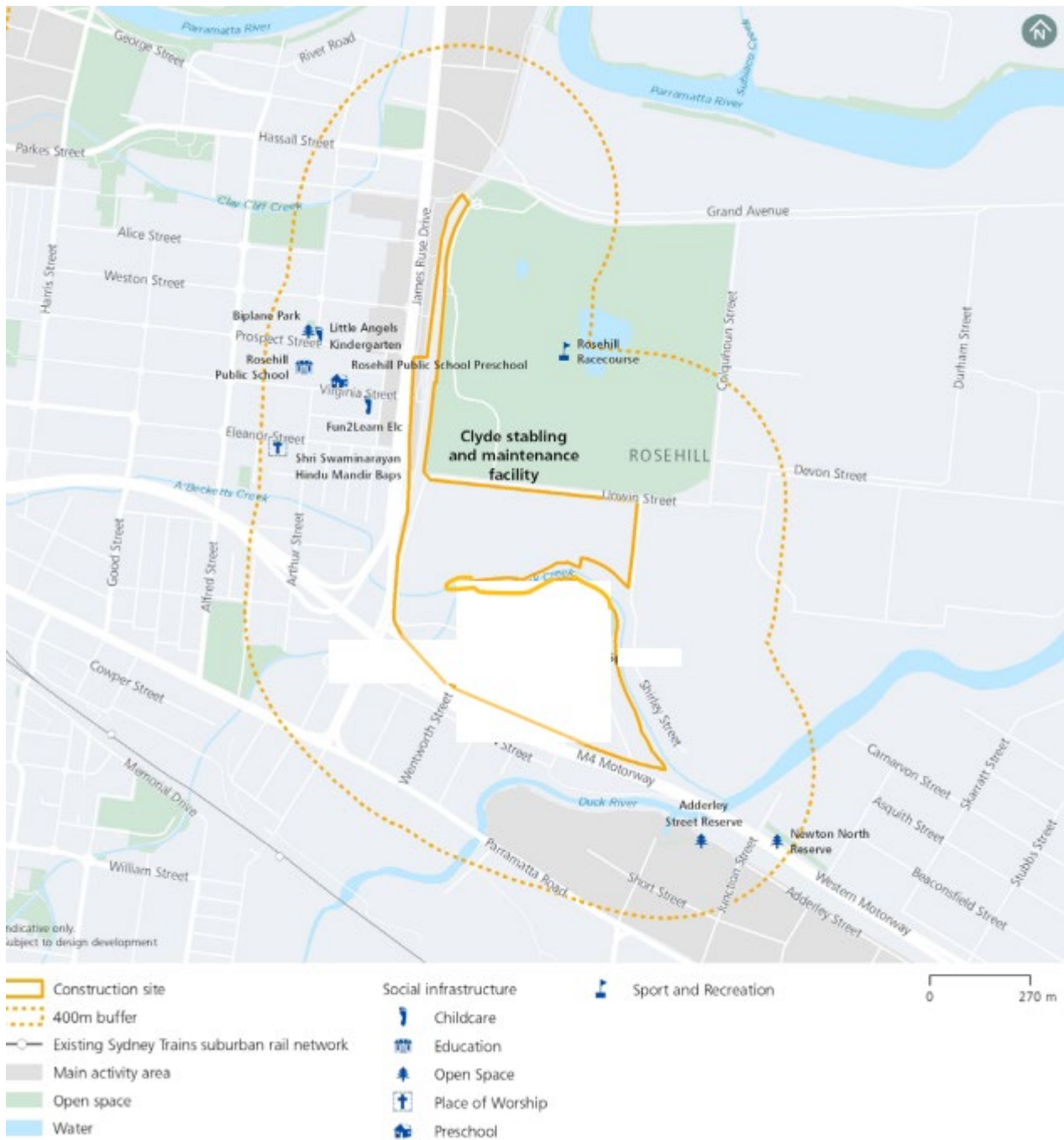

Figure 5-3: Sensitive receivers locations

Access to the M4 Motorway inbound carriageway is available from James Ruse Drive. Access to the M4 Motorway outbound carriageway is via the Great Western Highway/ Parramatta Road and Church Street. Egress from the M4 inbound carriageway is via Church Street, Great Western Highway/ Parramatta Road whilst egress from the M4 outbound carriageway is via James Ruse Drive, Great Western Highway/ Parramatta Road. All of these roads are classified as state roads as shown on Figure 5-4.



Figure 5-4: NSW Road Classification Map (source: [TfNSW Road Network Classification Map](#))

Surrounding the site, the road network is typically recognised as Performance Based Standard routes allowing the use of greater mass vehicles, refer to Figure 5-5. The use of PBS vehicles will reduce the number of vehicles required for the spoil haulage task in particular. This will be notable during the site operations phase of the project.

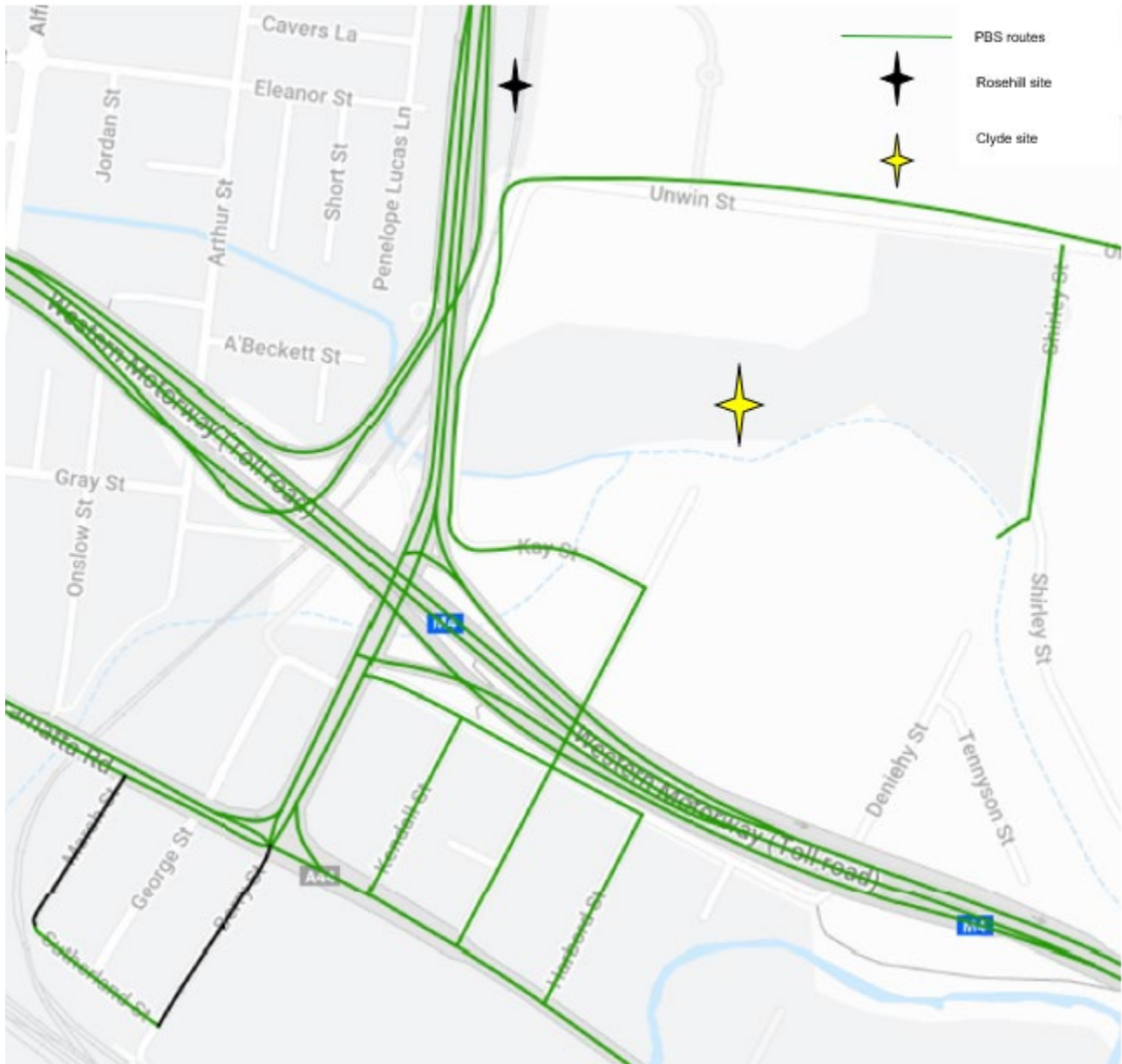

Figure 5-5: PBS Routes (source: [TfNSW PBS Network map](#))

5.2 Wentworth Street

Wentworth Street is a local road under the care and control of the City of Parramatta Council. It starts at the Great Western Highway/ Parramatta Road and ceases at A'becketts Creek, Clyde. Wentworth Street runs in a north south direction. The current speed limit is 50km/hr. The street previously contained a number of industrial uses on the western side between the M4 Motorway and A'becketts Creek, however, with the demolition works by Sydney Metro West, the western side of the streets will contain no premises north of the M4 Motorway overpass. On the eastern side of

the street Sydney Helicopters and the old Sydney Speedway were previously located. North of Kay Street, Wentworth Street has been acquired by Sydney Metro from the City of Parramatta Council and Sydney Metro West intends to license Wentworth Street from north of the M4 overpass from Council. All other land required for the construction and operation of the Sydney Metro West Stage 1 has been acquired by Sydney Metro.

Wentworth Street provides one of two main access/egress points into the Clyde area – the other being Grand Avenue north of Rosehill Gardens Racecourse. No public transport operates within the area or along Wentworth Street.

Traffic signals are located at the intersection of the Great Western Highway/ Parramatta Road, allowing all turn movements by providing a dedicated right turn bay on the Great Western Highway/ Parramatta Road for northbound traffic. A Left Turn on Red is permitted for vehicles egressing from Wentworth Street.

Signalised pedestrian crossings are provided across Wentworth Street and the Great Western Highway/ Parramatta Road (northern approach only). The Wentworth Street crossing includes a red arrow hold, so that vehicles on the Great Western Highway/ Parramatta Road waiting to turn left onto Wentworth Street are held during the pedestrian phase of the traffic signals.

Parking is typically unrestricted along Wentworth Street; however parking is restricted on the approach to the traffic signals on the Great Western Highway/ Parramatta Road intersection.

Wentworth Street has footpaths on both sides of the road the Great Western Highway/ Parramatta Road and the M4 Motorway overpass. Between the M4 Motorway overpass and A'becketts Creek, a footpath is only provided on the western side of the street.

A shared cycle path crosses Wentworth Street at its intersection with Martha Street. No dedicated crossing facilities are provided across Wentworth Street. This shared path is known as the M4 Motorway shared path which connects South Wentworthville in the west to Sydney Olympic Park in the east, refer to Figure 5-6.

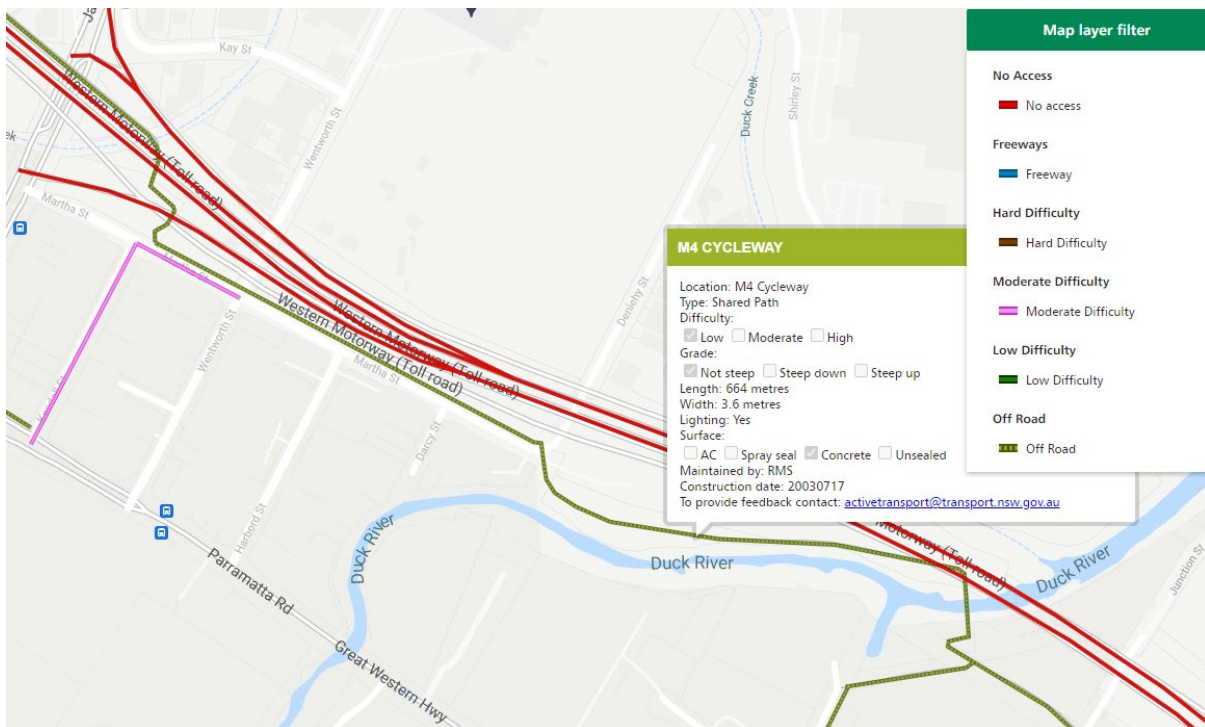

Figure 5-6: Existing shared path (source: [TfNSW Cycleway finder](#))

5.3 Kay Street

Kay Street is a local road under the care and control of the City of Parramatta Council. It starts at Wentworth Street and ceases at Unwin Street. Kay Street runs in an east west direction. The speed limit is 50km/hr. The street previously contained industrial uses on both sides of the street, however, with the demolition works by Sydney Metro West, all previous tenants have relocated. No public transport operates along Kay Street. Parking is unrestricted along Kay Street. Kay Street has footpaths on both sides of the street. A bridge over Duck Creek is located on Kay Street. It is noted that Sydney Metro intends to license Kay Street from the City of Parramatta Council for the Western Tunnelling Package of works.

5.4 Unwin Street

Unwin Street is a local road under the care and control of the City of Parramatta Council. It starts at Kay Street and ceases at Colquhoun Street. Unwin Street runs in a north south direction between Kay Street and Unwin Street and in an east west direction between Unwin Street and Colquhoun Street. The existing speed limit is 50km/hr. No public transport operates along Unwin Street. Parking is restricted on the western side between Kay Street and Unwin Street between the hours of 630AM-430PM Monday to Friday. There is a small section of 30 minute parking on Unwin Street opposite the Rosehill Gardens entry to the stables. Outside of these locations, parking is generally unrestricted.

Unwin Street between Kay Street and Unwin Street, on the eastern side of the street, also previously contained industrial uses which are vacant. The former Carlingford corridor was previously located to the immediate west of Unwin Street. This rail line was closed in January 2020. Fleet Street is located off Unwin Street. Fleet Street contains a TfNSW and provides a footpath connection to James Ruse Drive (western side). No public transport operates along Unwin Street.

Unwin Street between Unwin Street and Shirley Street on the southern side of the street, also previously contained industrial uses which has relocated. Rosehill Gardens Racecourse is located to the north of Unwin Street. The northern boundary of Unwin Street is bordered by Rosehill Gardens Racecourse.

Unwin Street has a footpath on the eastern side of Unwin Street between Kay Street and Unwin Street and a small section of footpath on the southern side of Unwin Street for approximately 160m from the north south section of Unwin Street.

A bridge over A'Becketts Creek is located on Unwin Street. It is noted that Sydney Metro intends to license Unwin Street from the City of Parramatta Council for the Western Tunnelling Package of works.

Speed management devices are located along the east-west section of Unwin Street, as noted on Figure 5-7.



Figure 5-7: Speed management device on Unwin Street

5.5 Shirley Street

Shirley Street is a local road under the care and control of the City of Parramatta Council. It starts at Unwin Street and ceases at Duck River. Shirley Street runs in a north south direction. The existing speed limit is 50km/hr. No public transport operates along Shirley Street. The street previously contained industrial uses on the west side of the street, however, with the demolition works by Sydney Metro West, these premises are no longer operating. Bulky goods premises are located on the eastern side of the street. No public transport operates along Shirley Street. Parking is generally unrestricted along Shirley Street with No Stopping provided towards Unwin Street on the western side. Footpaths are provided on the western side between Unwin Street and 130m south and the eastern side between Unwin Street and 280m south.

5.6 Martha Street

Martha Street is a local road under the care and control of the City of Parramatta Council. It starts at James Ruse Drive and ends at Deniehy Street. Martha Street runs east to west and has a speed

limit of 50km/hr. the street has industrial uses on the southern side and the M4 Motorway on the northern side. Parking is unrestricted along both sides of Martha Street. The M4 Motorway shared path is located on the northern side of Martha Street and a footpath is located on the southern side. At the eastern most end the shared path crosses across Martha Street to continue towards the east. There is no public transport along Martha Street.

5.7 Deniehy Street

Deniehy Street is a local road previously under the care and control of the City of Parramatta Council but this road is now under the Sydney Metro West ownership. Footpaths typically exist only under the M4 Motorway overpass. No public transport operates along Deniehy Street. The buildings in this area will be demolished and the street will be incorporated into the construction site. Parking is unrestricted.

5.8 Tennyson Street

Tennyson Street is a local road previously under the care and control of the City of Parramatta Council but this road is now under the Sydney Metro West ownership. Footpaths do not exist. No public transport operates along Deniehy Street. The buildings in this area will be demolished and the street will be incorporated into the construction site. Parking is unrestricted.

6 SITE OPERATIONS

All work vehicles will enter and exit the construction sites in a forward direction, where reasonable and feasible. Where this is not possible, appropriate management measures will be put in place such as traffic control.

6.1.1 Impact on traffic flow

GLC will ensure that impacts to traffic flow are minimised by:

- Centralised logistics team and monitoring area to identify and regulate truck operations
- Monitoring of access/egress points via Closed Circuit Television (CCTV)
- Managing truck movements along discrete routes to minimise cumulative haulage impacts
- Scheduling where feasible, to avoid operating school zones and high pedestrian activity areas
- Use of Teletrac Navman for real time tracking of vehicles and loads including compliance of vehicles to haul routes, speed limits and mass requirements

6.1.2 Impact on parking

All light and heavy vehicles associated with the works will be catered for on site.

6.1.3 Impact on active transport users

The existing M4 shared path, refer to Figure 5-6, runs along Martha Street requiring crossing of Wentworth Street and at the site entry into Deniehy Street from Martha Street. To ensure that heavy vehicle driver are aware of the presence. Signage had previously been installed by the early works contractor along Wentworth Street and on Martha Street approaching Wentworth Street. Further signage is proposed to be installed on Martha Street and Deniehy Street to highlight the existence of the shared path crossing point and on the shared path it is proposed to install the existing TfNSW Truck Aware decals. This signage and decal is shown below on Figure 6-1.



Figure 6-1: Shared path warning sign and truck decals

The locations of the signs and proposed decals are shown on Figure 6-2.

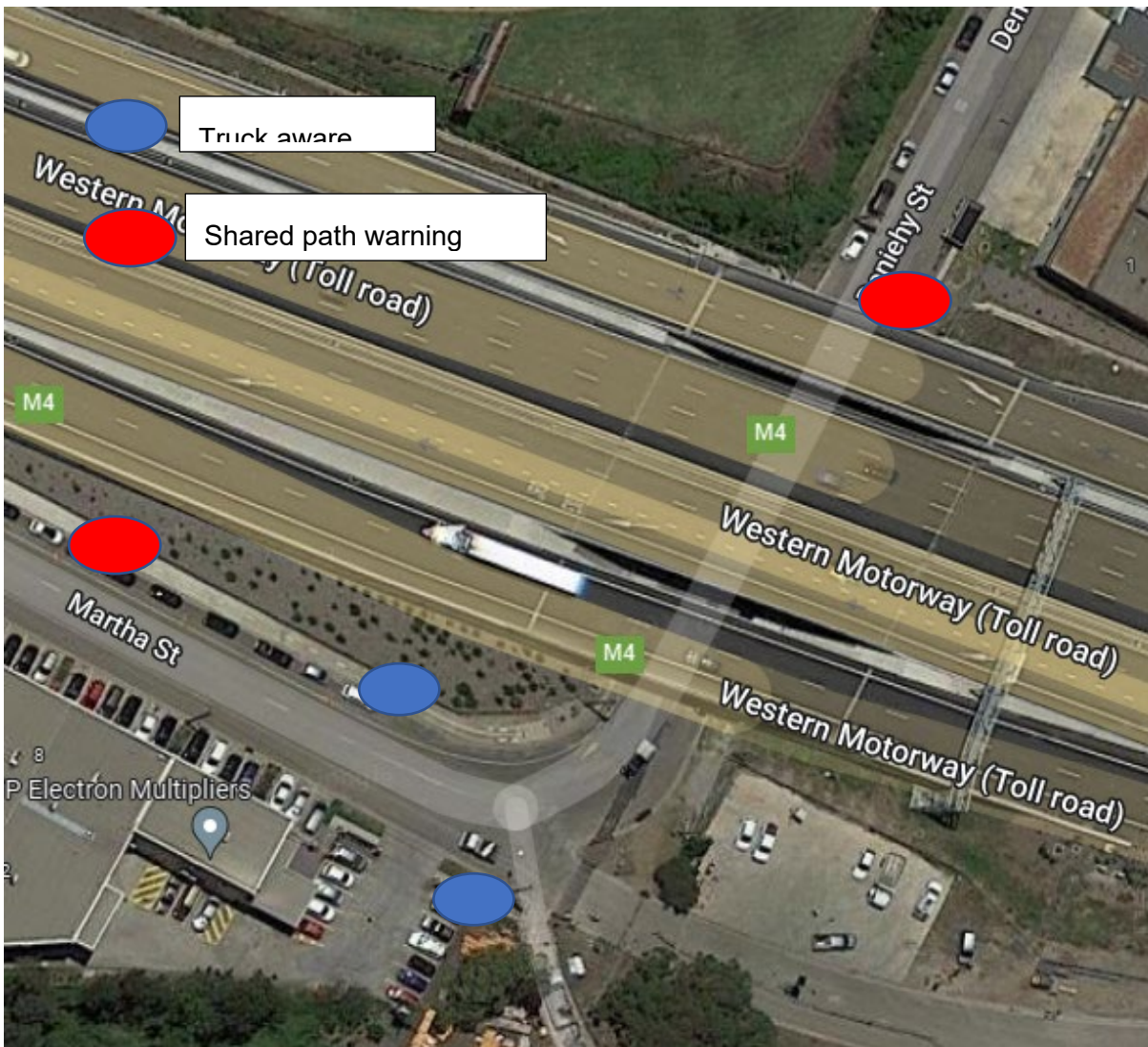

Figure 6-2: Sign and decal locations

6.1.4 Managing cumulative impacts

No works have been identified near the Clyde/ Rosehill work sites. The Parramatta Light Rail worksites are located north of Rosehill Gardens Racecourse with their entry being Grand Avenue. To ensure that GLC are aware of other projects and/ or impacts, GLC will attend the following forums.

6.1.4.1 Traffic and Transport Liaison Group (TTLG)

This forum is provided to ensure that the stakeholders who may be affected by the works are informed of the proposed works and the traffic impacts associated with those works. Attendance at these forums typically includes several government agencies at both the state and local level, emergency services, public and private transport operators, pedestrians and cyclists advocacy groups and other stakeholders as nominated by TfNSW. This forum typically meets monthly.

6.1.4.2 Traffic Control Group (TCG)

The TCG is a forum to discuss the proposed traffic management measures during the stages of the works including the impacts on the road and transport network and proposed mitigation measures, any feedback received on the traffic documentation and updates on the program of works. This group will meet as agreed between the members. The TCG members will vary depending on the location of the works. Proposed members include:

- Transport for New South Wales including Sydney Metro; Transport Management Centre: Customer Journey Planning (previously SCO); Greater Sydney Region (previously RMS)
- Local council representatives
- Other contractors required by TfNSW
- Centre of Road and Maritime Safety
- Infrastructure NSW.

7 FLEET MANAGEMENT

Trucks to be used on the project will be compliant with NSW legislation, Sydney Metro's Principal Contractor Health and Safety Standard, relevant Australian Design Rules and vehicle standards and the Heavy Vehicle National Legislation. All heavy vehicle operations will be conducted in accordance with GLC's Chain of Responsibility (CoR) Management Plan including compliance with nominated haulage routes.

A combination of truck types will be used during the works, with trucks being truck and dog, semi-trailers, 12.5m single unit trucks and low loaders. Table 10-4 of Chapter 10 Traffic and Transport notes the vehicle types to be used at the Clyde Rosehill site, as noted below.

Table 10-4: Construction vehicle types

Construction site	Truck type ¹
Westmead metro station	Rigid truck and/or truck and dog
Parramatta metro station	Rigid truck and/or truck and dog
Clyde stabling and maintenance facility	Rigid truck and/or truck and dog
Silverwater services facility	Rigid truck and/or truck and dog
Sydney Olympic Park metro station	Rigid truck and/or truck and dog
North Strathfield metro station	Rigid truck and/or truck and dog
Burwood North Station	Rigid truck and/or truck and dog Medium rigid truck
Five Dock Station	Rigid truck and/or truck and dog
The Bays Station	Rigid truck and/or truck and dog

All vehicles will enter and exit the site in a forward direction.

Construction traffic will be managed to minimise movements during peak periods and through school zones during drop off and pick up times, in particular at the Westmead and Parramatta sites and this will be achieved through scheduling of vehicles and staggered start and finish times. GLC will ensure that there is no idling or queuing on public roads by providing sufficient on site areas for vehicles to wait. The use of marshalling facilities is not envisioned, however, where this is required, GLC will ensure that the marshalling of heavy vehicles is not carried out near sensitive land user(s).

7.1 Road dilapidation report

Before any local road is used by Heavy Vehicles, a road dilapidation report will be prepared. A copy of that report will be provided to the City of Parramatta Council within three (3) weeks of completion of the survey and no later than one (1) month before the road used by heavy vehicles associated with the project.

If damage to roads occurs as a result of the construction of the project, GLC will either, at City of Parramatta Council's discretion:

- Compensate the City of Parramatta Council for the damage so caused or
- Rectify the damage to restore the road to at least the condition it was in pre-work as identified in the Road Dilapidation Report

7.2 Drivers and operators

Operator selection will be based on safety performance criteria. Operators and drivers will be required to have general construction industry induction cards and will be required to attend ongoing general project and site specific inductions.

All operators will be comprehensively trained with regard to community expectations and impacts from heavy vehicle movements through site inductions and attendance at the Sydney Metro Industry Curriculum (SMIT) – Safe Heavy Vehicle Introduction Skills which provides drivers with the knowledge, skills, motivation and confidence to drive heavy vehicles safely and professionally in an urban built up road environments, whilst undertaking a transport task required on the project. The training course focuses on low risk driver behaviours, shared the road safely with vulnerable road users and reinforces heavy vehicle driver knowledge and skill. The project and site inductions will have a particular focus on operator behaviour. The driver induction process will include safety awareness in relation to all road users, particularly pedestrians and cyclists.

7.3 Proposed vehicle movements

Heavy vehicles will transport materials from the work site to authorised disposal sites, where the material is unable to be reused on site. The number of vehicles associated with the Clyde/ Rosehill sites is dependent on the task to be undertaken, as noted in the EIS the site establishment works noted 32 vehicle movements per hour between the hours of 7AM-5PM, equating to 16 trucks per hour, whilst the piling and excavation works, Phase 2 as noted in the EIS, will see vehicle movements per hour, over a 24 hour period. The largest transport task will be associated with the Phase 3 works that include excavation and Tunnel Boring Machine, spoil removal, refer to Figure 7-1.

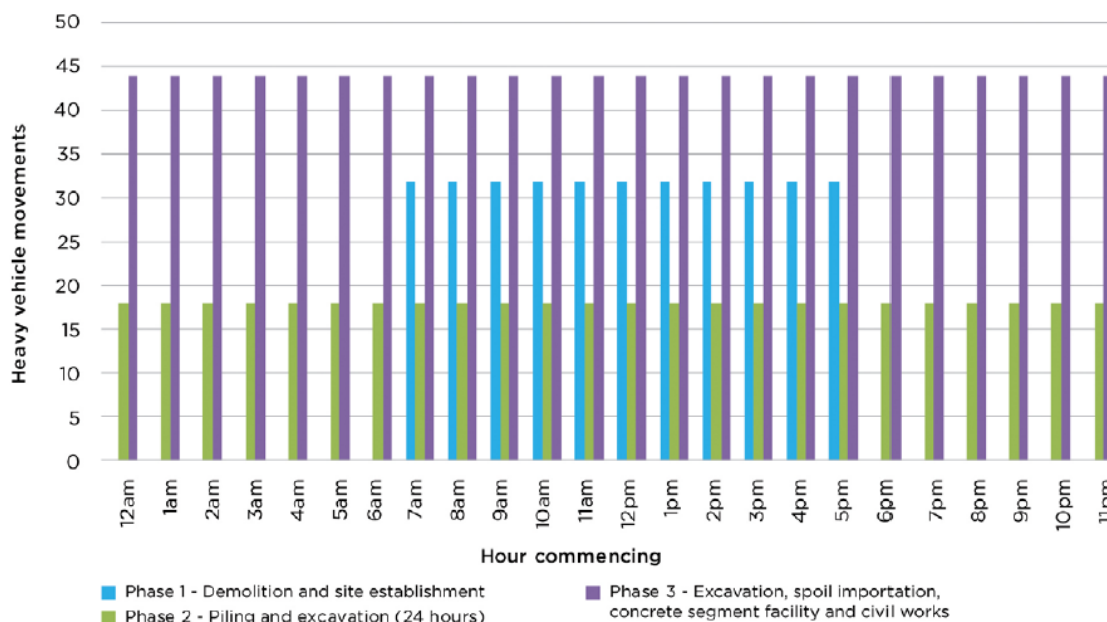

Figure 10-14: Hourly heavy vehicle movements at the Clyde stabling and maintenance facility construction site

Note: Movement means a one way movement. A truck entering and then leaving a work site represents 2 movements.

Figure 7-1: EIS Heavy Vehicle moments (source: Chapter 10 EIS)

The heavy vehicle numbers proposed for the Clyde/ Rosehill site for the various phases of the works as noted in Table 3. It should be noted that the heavy vehicle numbers are significantly less than those noted in the EIS.

Table 3: Heavy Vehicle movements per hour per phase of works

Phase of works	Working hours	EIS#	GLC#
1	7AM-6PM Mon-Sat	32	10
2	24 hours	18	12
3	24 hours	44	20

7.4 EIS routes for Heavy Vehicles

The EIS nominated Wentworth Street between the Great Western Highway/ Parramatta Road and the M4 Motorway overpass, as the heavy vehicle haulage routes into the site as shown on Figure 7-2.

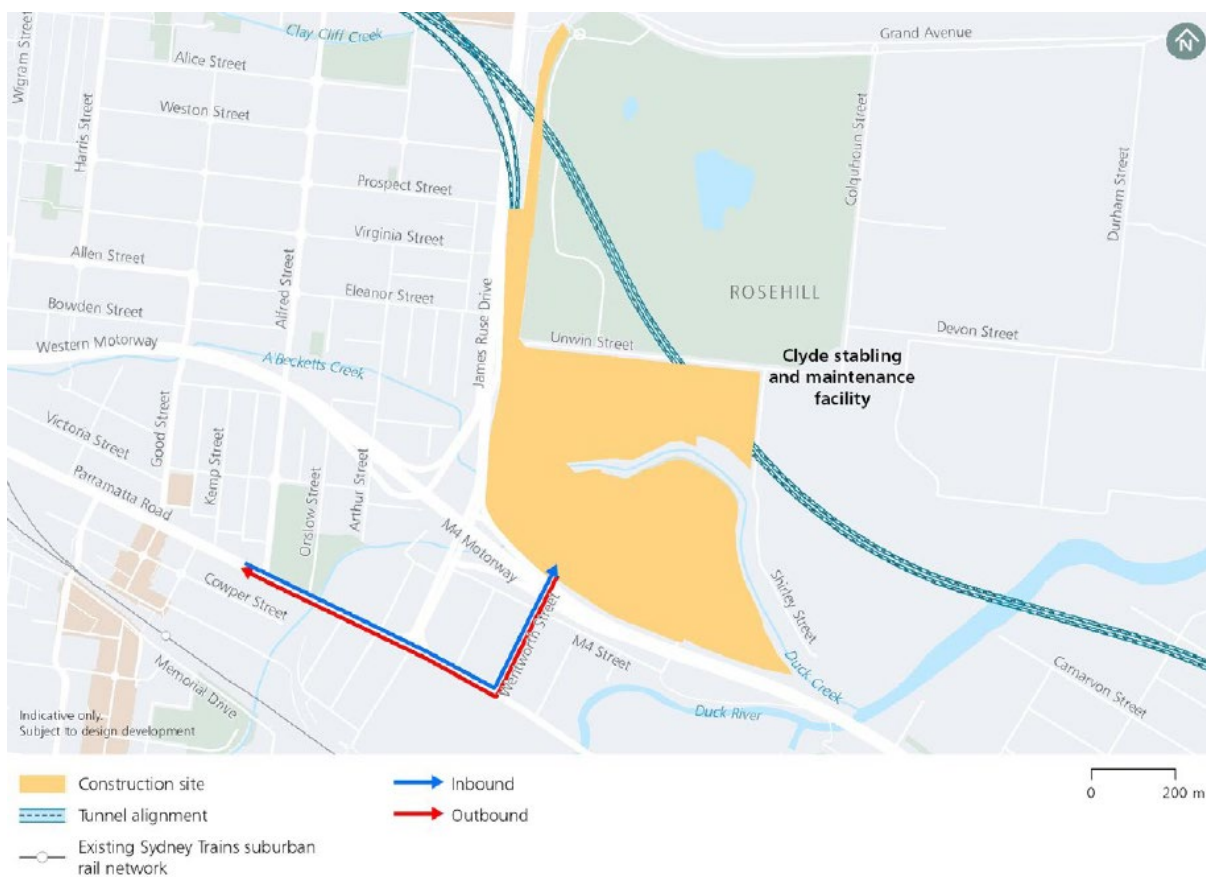

Figure 7-2: EIS nominated heavy vehicle routes

As noted the use of Wentworth Street is only nominated between the Great Western Highway/ Parramatta Road through to the M4 Motorway overpass.

7.5 Proposed heavy vehicle routes

There are a number of local roads within the Clyde/ Rosehill area that are required to access/ egress the construction site. These roads are detailed in Table 4.

Table 4: Roads to be used by Heavy Vehicles

Road name	Between	Between	Classification	Two way traffic flow	Parking	Speed limit
Wentworth Street	M4 Motorway Overpass	Duck Creek	Local	Yes	Yes	50km/hr
Kay Street	Wentworth Street	Unwin Street	Local	Yes	Yes	50km/hr
Unwin Street	Kay Street	Shirley Street	Local	Yes	Yes	50km/hr
Shirley Street	Unwin Street	Duck Creek	Local	Yes	Yes	50km/hr
Martha Street	Wentworth Street	Deniehy Street	Local	Yes	Yes	50km/hr
Deniehy Street	Martha Street	End of road	Local	Yes	Yes	50km/hr
Tennyson Street	Deniehy Street	End of road	Local	Yes	Yes	50km/hr

7.6 Fleet safety

GLC is committed to safety for all aspects of the project with road safety being paramount to the success of the project. To demonstrate this commitment the requirements listed in Table 5.

Table 5: Heavy vehicle requirements

Requirement(s)	Purpose	Managed by
Ensure all heavy vehicles are registered and comply with the Australian Design Rules	Ensure compliance with legislative requirements	Checking prior to attendance at site through subcontractor engagement All vehicles will be registered on Plant Assessor
Blind spot elimination or minimise front, side and rear blind spots, including	Ensure compliance with SWTC and increase visibility of active transport users	Checking prior to attendance at site through subcontractor engagement

Requirement(s)	Purpose	Managed by
<ul style="list-style-type: none"> Class V and VI mirrors as per ADR14.02 where blind spots cannot be permanently eliminated The prohibition of accessories that restrict the forward field of vehicles including opaque or chrome bug deflectors 		All vehicles will be registered on Plant Assessor
<p>Side underrun protection fitted to both sides of the vehicle:</p> <ul style="list-style-type: none"> Between the front and rear axle of all rigid (SU) trucks and Between the front axle/ landing legs and rear axle of trailers forming part of a combination 	Improved protection for active transport users	<p>Checking prior to attendance at site through subcontractor engagement</p> <p>All vehicles will be registered on Plant Assessor</p>
<p>Signage placed on heavy vehicles including:</p> <ul style="list-style-type: none"> Rear warning signs alerting other roads users to the dangers of overtaking and Front nearside signs warning pedestrians about walking close to the front of a moving or stationary heavy vehicle 	Increasing road safety awareness for all users	<p>Checking prior to attendance at site through subcontractor engagement</p> <p>All vehicles will be registered on Plant Assessor</p>
Full body line and contour conspicuity markings and reflective markings fitted to the drawbar of all trailers	Increasing visibility of heavy vehicles	<p>Checking prior to attendance at site through subcontractor engagement</p> <p>All vehicles will be registered on Plant Assessor</p>
Heavy vehicle drivers to complete the Sydney Metro Safe Heavy Vehicle Driver Induction program or similar	Training and induction to address safety of pedestrians/ cyclists along street frontages	<p>Training and induction process</p> <p>All heavy vehicle operators will be registered on Plant Assessor</p>

Requirement(s)	Purpose	Managed by
All heavy vehicles used for spoil haulage must be clearly marked on the sides and rear with the project name and application number to enable immediate identification by a person viewing the heavy vehicle standing 20m away	Compliance with MCoA	Checking prior to attendance at site through subcontractor engagement All vehicles will be registered on Plant Assessor

8 COMMUNITY AND CONSULTATION

8.1 Stakeholders

Table 6 notes the consultation undertaken in the development of this Heavy Vehicle Local Road report. Appendix C includes the comments received and GLC's responses to those comments.

Table 6: Stakeholder consultation

Stakeholder	Date	Consultation
TCG	17 th March 2022	Presentation
TTLG	31 st March 2022	Presentation
Sydney Metro Project team	1 st April 2022	Submission of HVLR report
CJP	1 st April 2022	Submission of HVLR report
City of Parramatta Council	1 st April 2022	Submission of HVLR report
Sydney Metro Project team	16 May 2022	Resubmission of HVLR report
CJP	16 May 2022	Resubmission of HVLR report
City of Parramatta Council	16 May 2022	Resubmission of HVLR report
Sydney Metro Project team	7 June 2022	Resubmission of HVLR report
CJP	7 June 2022	Resubmission of HVLR report
City of Parramatta Council	7 June 2022	Resubmission of HVLR report

8.2 Workforce communications

All personnel, including subcontractors, are required to attend a compulsory project and site induction before commencing any works on site. Similarly, visitors will be required to undertake a visitor's induction. This HVLR report will be included in the Construction Traffic Management Plan (CTMP) and will be included in the site induction for heavy vehicle drivers. A record of all attendees will be maintained.

Toolbox talks will be conducted and will be used to promote the safety and environmental performance including compliance with this report and the approved CTMP.

A : SWEEP PATH ANALYSIS

Swept path analysis was undertaken at the locations as noted on Figure 8-1 and included in Table 6.

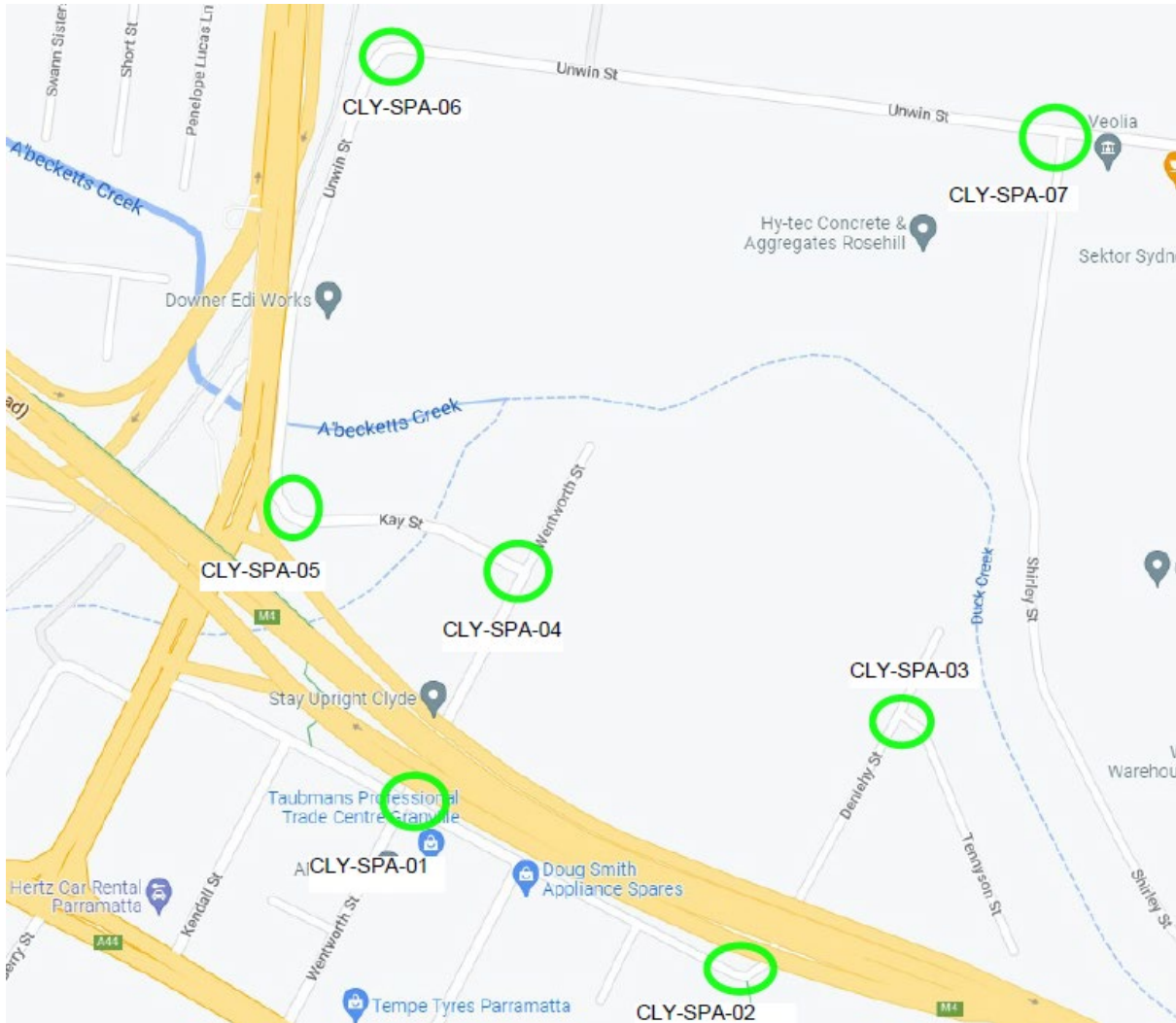
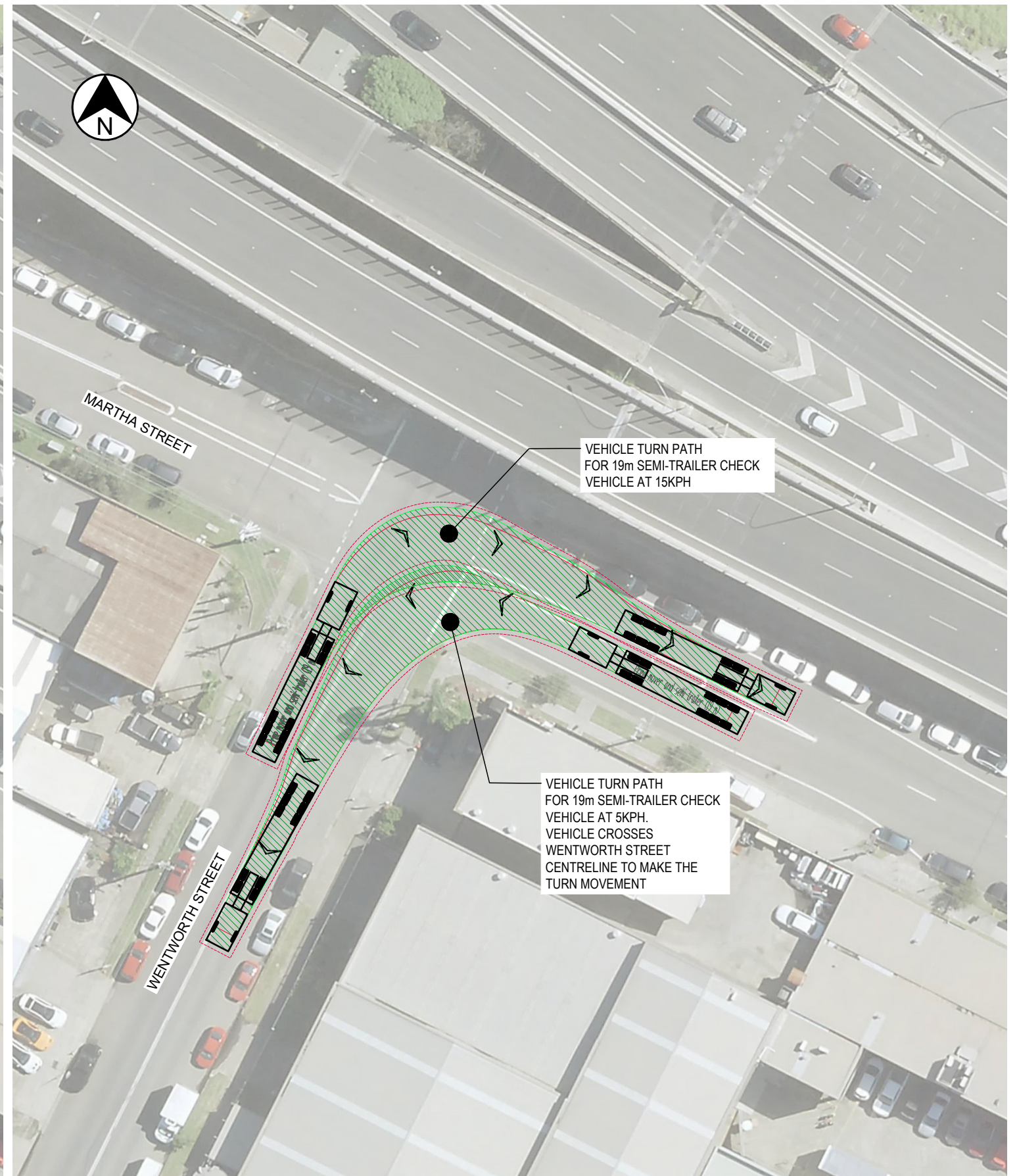
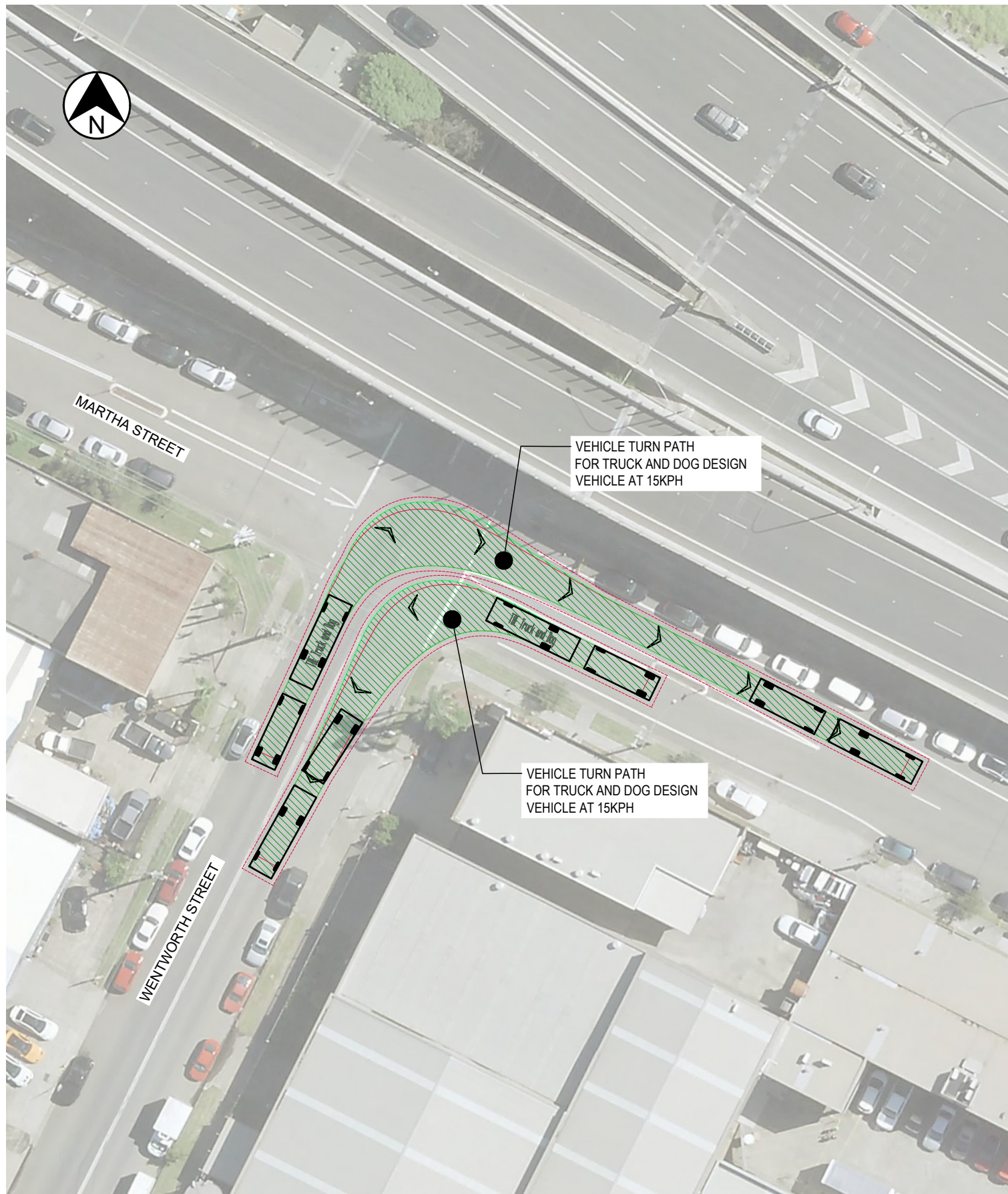

Figure 8-1: Swept path analysis locations

Table 7: Swept path drawing and suitability

Drawing #	Location	Suitability	Truck type
CLY-SPA-01	Wentworth St at Martha St	Yes	Truck and dog
CLY-SPA-01	Wentworth St at Martha St	No - Encroaches into opposing carriageway	Semi-trailer
CLY-SPA-02	Martha St at Deniehy St	Yes	Both
CLY-SPA-03	Deniehy St at Tennyson St	Yes	Both
CLY-SPA-04	Wentworth St at Kay St	Yes	Both
CLY-SPA-05	Kay St at Unwin St	Yes	Both
CLY-SPA-06	Unwin St at Unwin St	Yes	Both
CLY-SPA-07	Unwin St at Shirley St	Yes	Truck and dog
CLY-SPA-07	Unwin St at Shirley St	No - Encroaches into opposing carriageway	Semi-trailer



VEHICLE TURN PATH LEGEND

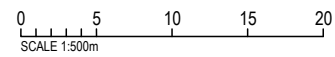
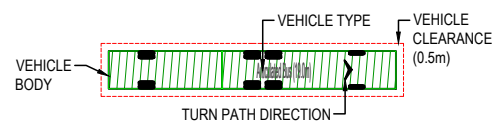

CLY-SPA-01

SYDNEY METRO
WESTERN TUNNELING WORKS
MARtha STREET / WENTWORTH STREET

FOR INFORMATION ONLY

turnbull

220324 WTW Swept Paths.dwg

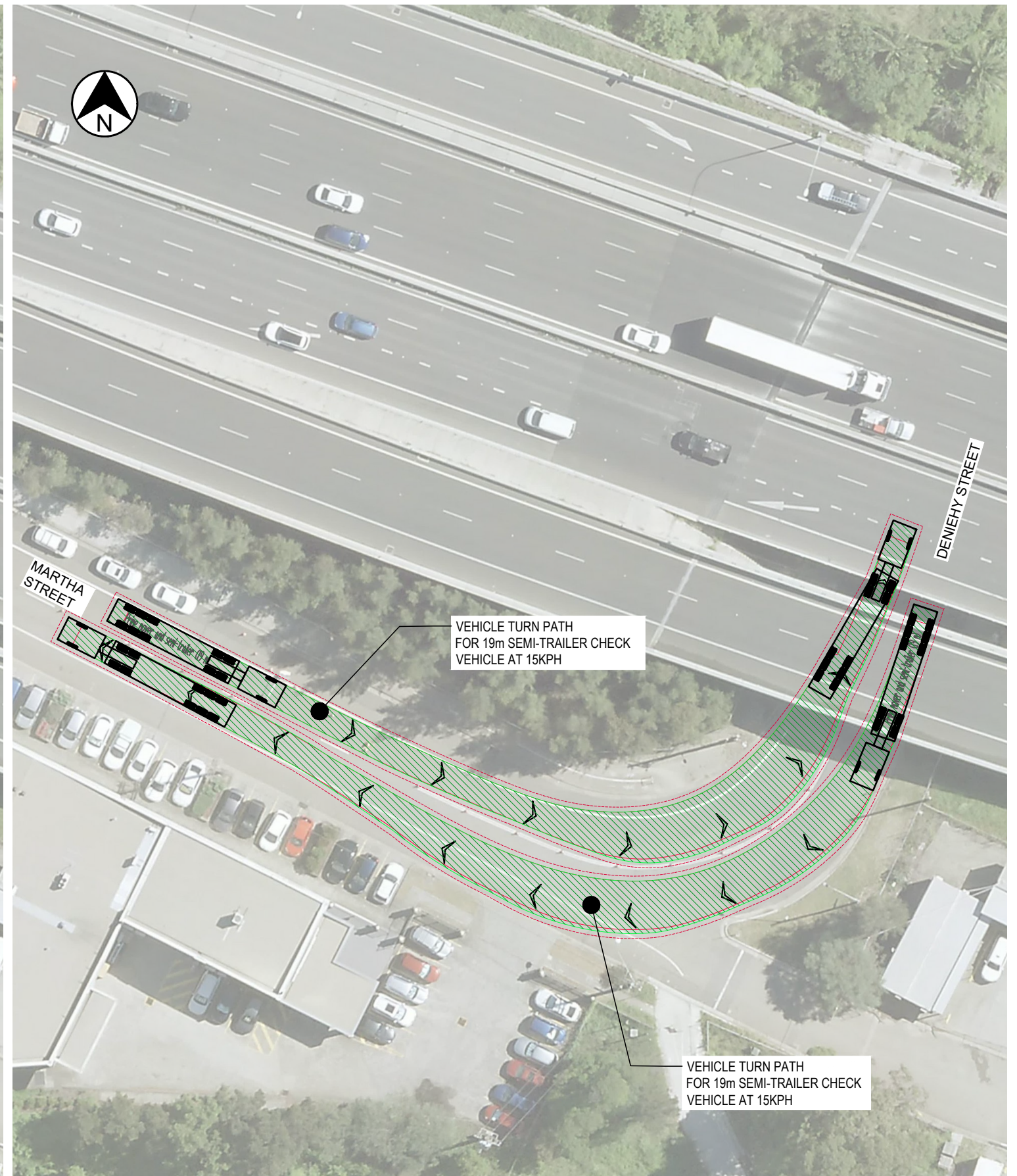
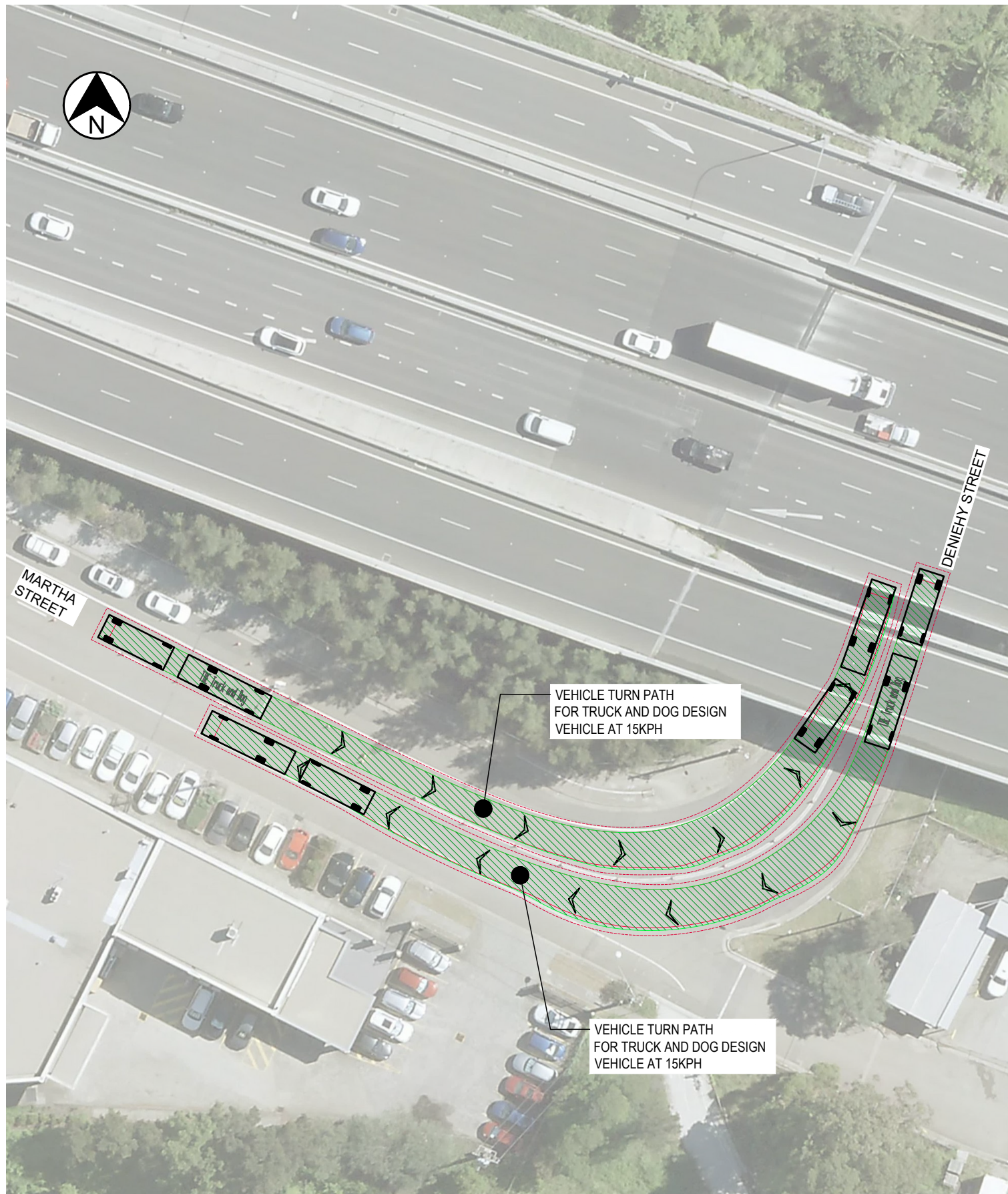

VEHICLE TURN PATH LEGEND

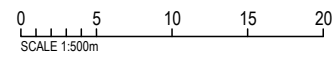
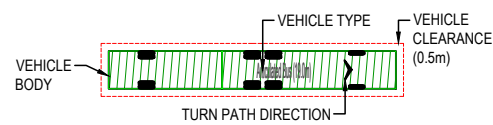

CLY-SPA-02

SYDNEY METRO
WESTERN TURNNELING WORKS
MARtha STREET / DENIEHY STREET

FOR INFORMATION ONLY

turnbull

220324 WTW Swept Paths.dwg

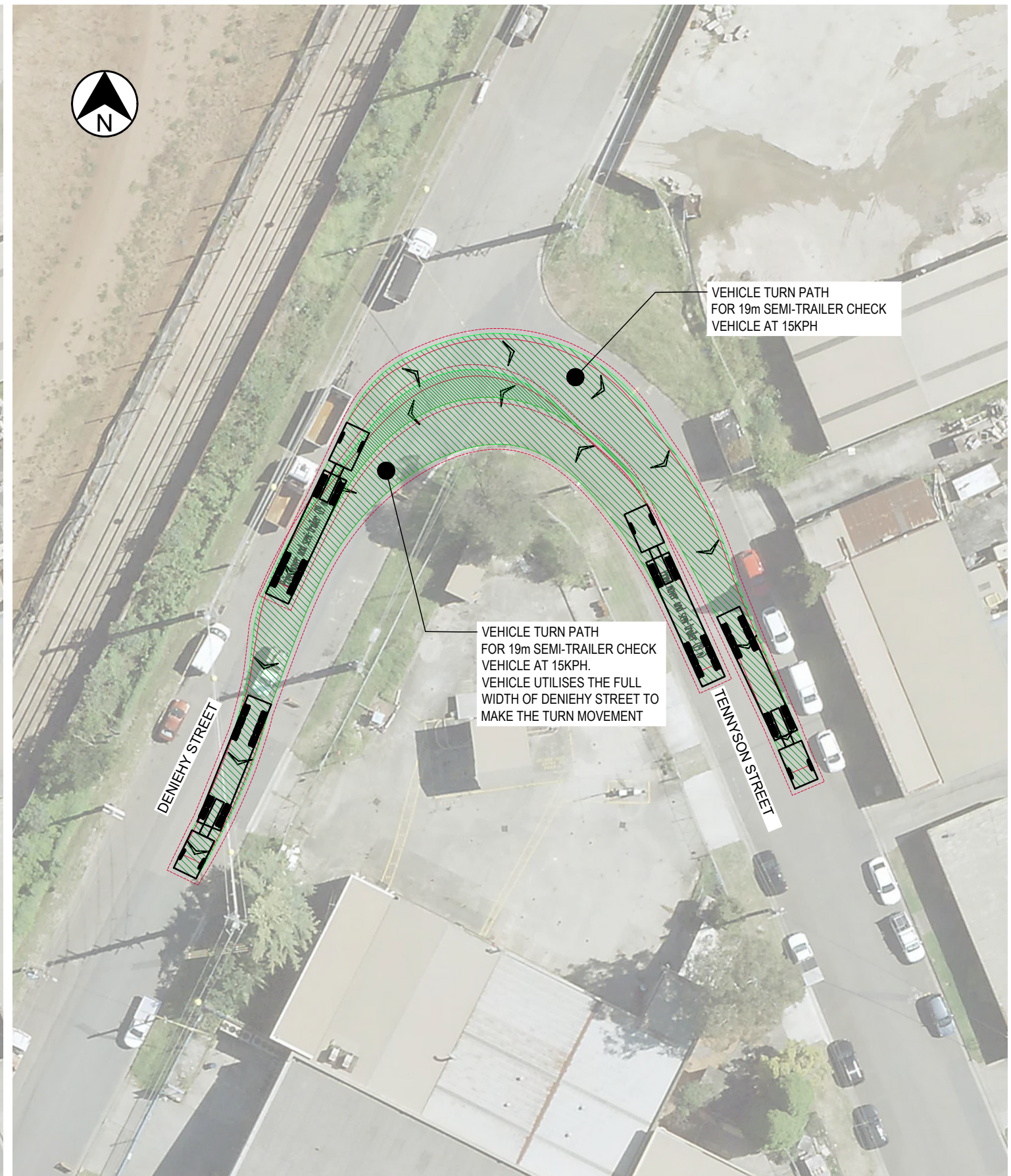
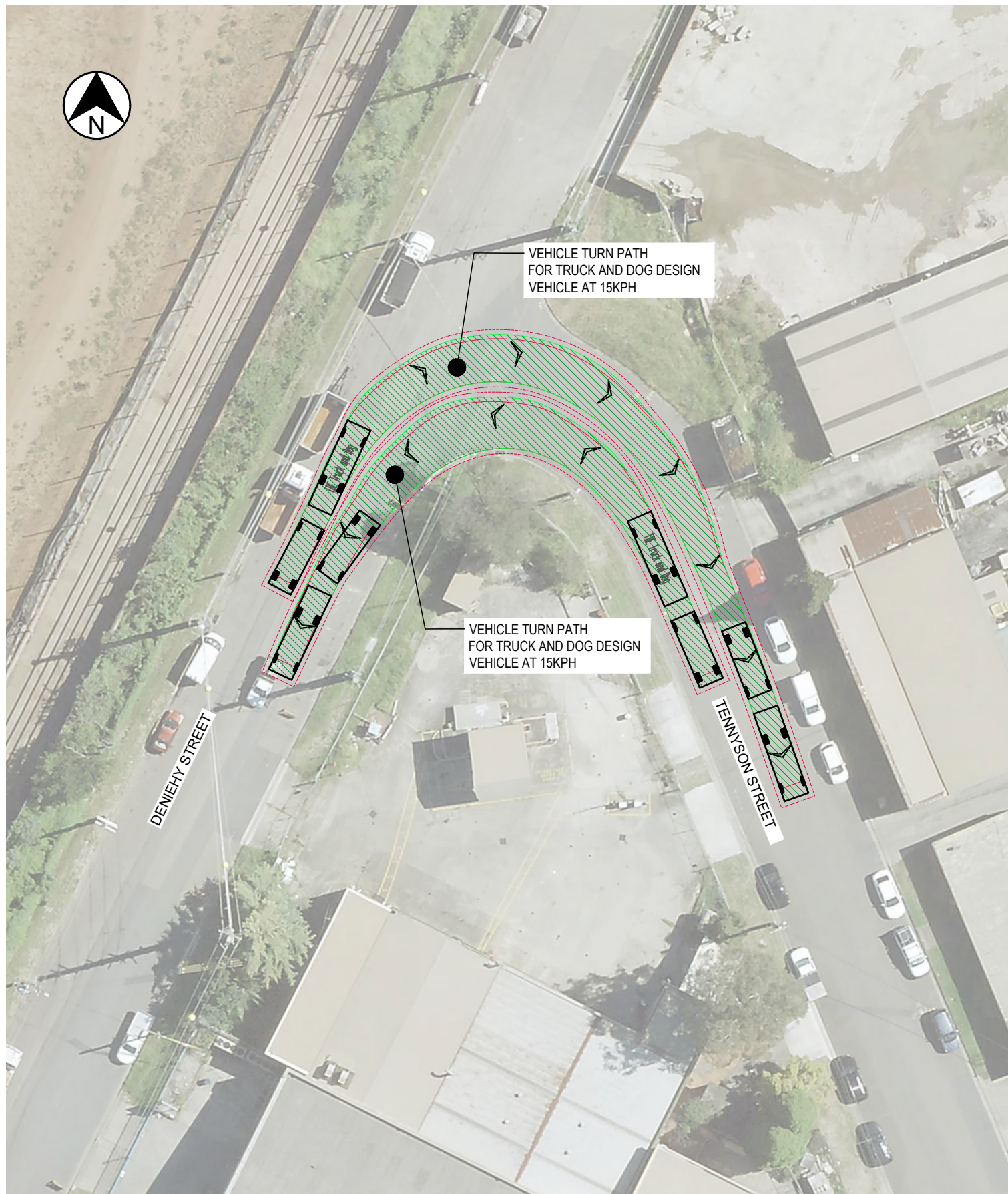

VEHICLE TURN PATH LEGEND

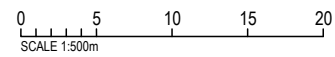
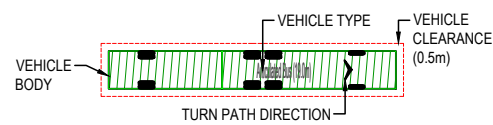

CLY-SPA-03

SYDNEY METRO
WESTERN TURNNELING WORKS
DENIEHY STREET / TENNYSON STREET

FOR INFORMATION ONLY

turnbull

220324 WTW Swept Paths.dwg



KAY ST

KAY ST

WENTWORTH ST

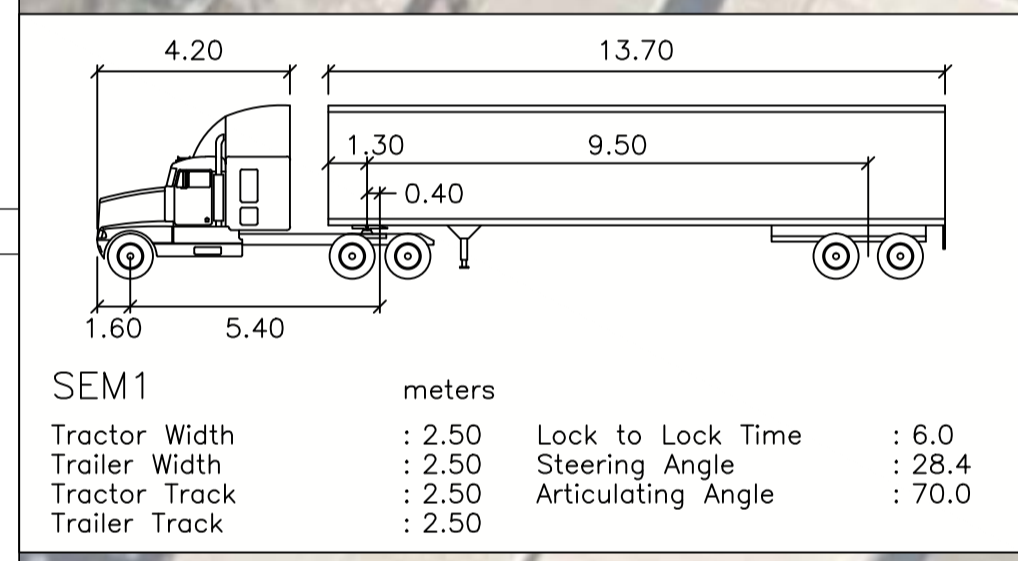

GENERAL NOTES
 - 500MM VEHICLE BODY SHOWN WITH DASHED LINE
 - DESIGN VEHICLE SWEEP PATH COMPLETED AT 10KPH
 - ALL SWEEP PATHS COMPLETED ON SCALED AERIAL IMAGERY AND SHOULD BE VARIFIED ON SITE PRIOR TO HAULAGE OPERATIONS

REV	BY	DATE	DESCRIPTION	APPD.
A	SS	16/08/21	INITIAL DRAFT	SL
COORDINATE SYSTEM:			HEIGHT DATUM:	SCALE:

DRAWN BY:	SS	PROJECT
DRW CHECK:	SL	
APPROVED:	SL	
IND REVIEW:	SL	



CLYDE
SWEEP PATH ANALYSIS

DRAWING No:	CLY-SPA-04		
	Semi-trailer		
SHEET	1	OF	1
REVISION	A		



GENERAL NOTES
 - 500MM VEHICLE BODY SHOWN WITH DASHED LINE
 - DESIGN VEHICLE SWEEP PATH COMPLETED AT 10KPH
 - ALL SWEEP PATHS COMPLETED ON SCALED AERIAL IMAGERY AND SHOULD BE VARIFIED ON SITE PRIOR TO HAULAGE OPERATIONS

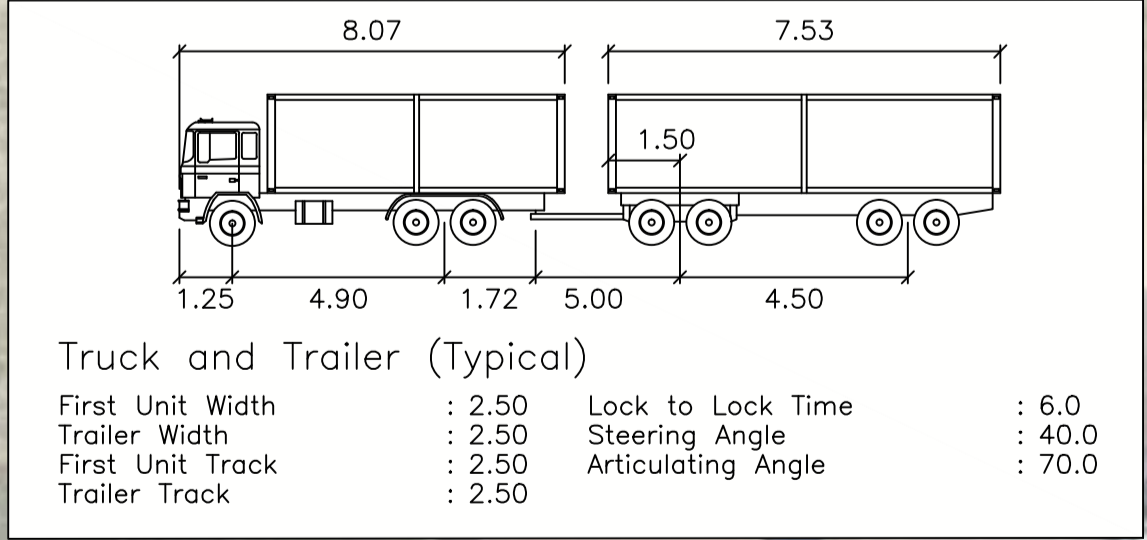

REV	BY	DATE	DESCRIPTION	APPD.
A	SS	16/08/21	INITIAL DRAFT	SL
COORDINATE SYSTEM:			HEIGHT DATUM:	SCALE:

DRAWN BY:	SS
DRW CHECK:	SL
APPROVED:	SL
IND REVIEW:	SL

PROJECT
 CLIENT



CLYDE
 SWEEP PATH ANALYSIS

DRAWING No:	CLY-SPA-04	
	Truck and dog	
SHEET	1	OF 1
REVISION	A	

GENERAL NOTES
 - 500MM VEHICLE BODY SHOWN WITH DASHED LINE
 - DESIGN VEHICLE SWEEP PATH COMPLETED AT 10KPH
 - ALL SWEEP PATHS COMPLETED ON SCALED AERIAL IMAGERY AND SHOULD BE VERIFIED ON SITE PRIOR TO HAULAGE OPERATIONS

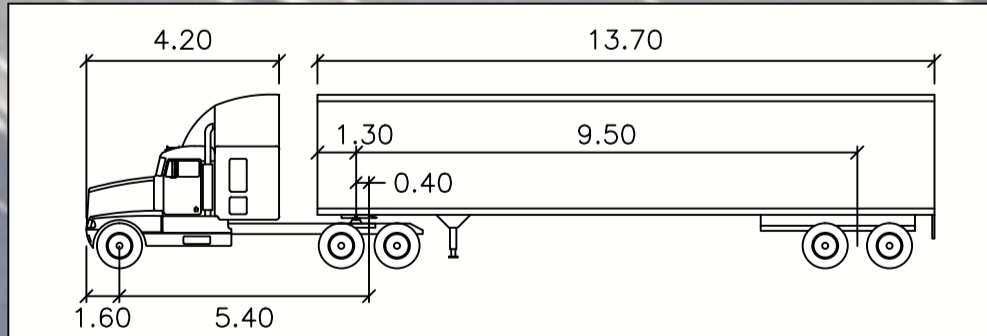

SEM1		meters	
Tractor Width	: 2.50	Lock to Lock Time	: 6.0
Trailer Width	: 2.50	Steering Angle	: 28.4
Tractor Track	: 2.50	Articulating Angle	: 70.0
Trailer Track	: 2.50		

3.0
10.0
70.0

DRAWN BY:	SS
DRW CHECK:	SL
APPROVED:	SL
IND REVIEW:	SL

PROJECT

CLIENT



CLYDE SWEEP PATH ANALYSIS

DRAWING No:	CLY-SPA-05		
	Semi-trailer		
SHEET	1	OF	1
REVISION	A		

REV	BY	DATE	DESCRIPTION	APPD.
A	SS	16/08/21	INITIAL DRAFT	SL

COORDINATE SYSTEM:	HEIGHT DATUM:	SCALE:
--------------------	---------------	--------

GENERAL NOTES
 - 500MM VEHICLE BODY SHOWN WITH DASHED LINE
 - DESIGN VEHICLE SWEEP PATH COMPLETED AT 10KPH
 - ALL SWEEP PATHS COMPLETED ON SCALED AERIAL IMAGERY AND SHOULD BE VERIFIED ON SITE PRIOR TO HAULAGE OPERATIONS

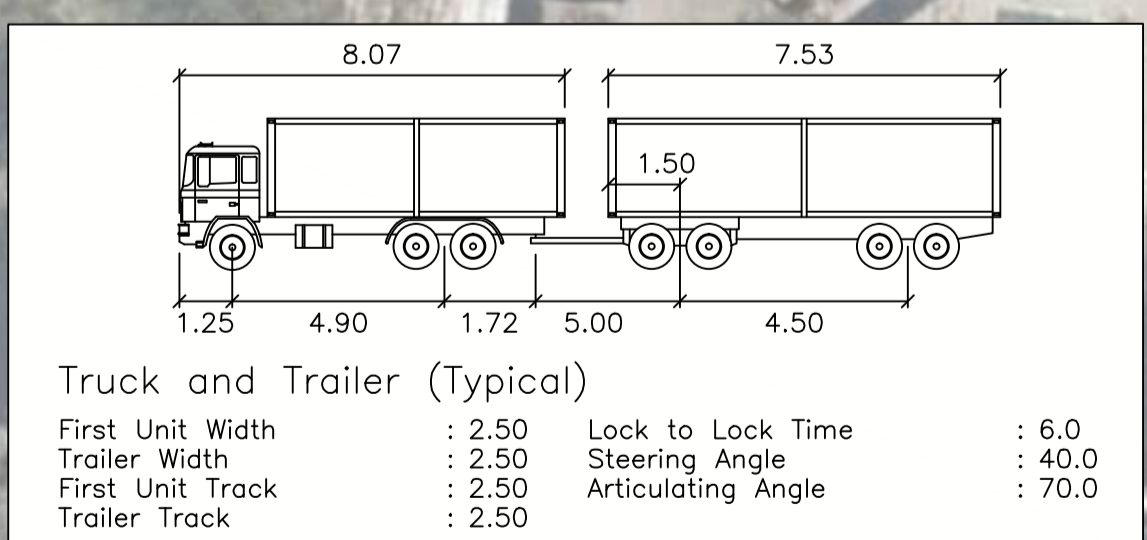

DRAWN BY: SS
 DRW CHECK: SL
 APPROVED: SL
 IND REVIEW: SL

PROJECT
 CLIENT



CLYDE
 SWEEP PATH ANALYSIS

DRAWING No: **CLY-SPA-06**
Truck and dog
 SHEET **1** OF **1**
 REVISION **A**

REV	BY	DATE	DESCRIPTION	APPD.
A	SS	16/08/21	INITIAL DRAFT	SL

COORDINATE SYSTEM: HEIGHT DATUM: SCALE:

GENERAL NOTES
 - 500MM VEHICLE BODY SHOWN WITH DASHED LINE
 - DESIGN VEHICLE SWEEP PATH COMPLETED AT 10KPH
 - ALL SWEEP PATHS COMPLETED ON SCALED AERIAL IMAGERY AND SHOULD BE VARIFIED ON SITE PRIOR TO HAULAGE OPERATIONS

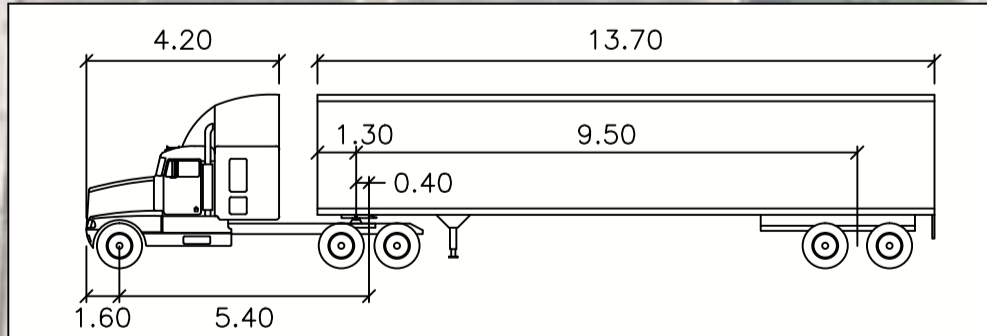

SEM1		meters	
Tractor Width	: 2.50	Lock to Lock Time	: 6.0
Trailer Width	: 2.50	Steering Angle	: 28.4
Tractor Track	: 2.50	Articulating Angle	: 70.0
Trailer Track	: 2.50		

REV	BY	DATE	DESCRIPTION	APPD.
A	SS	16/08/21	INITIAL DRAFT	SL
COORDINATE SYSTEM:			HEIGHT DATUM:	SCALE:

DRAWN BY:	SS
DRW CHECK:	SL
APPROVED:	SL
IND REVIEW:	SL

PROJECT
 CLIENT



CLYDE
 SWEEP PATH ANALYSIS

DRAWING No:		CLY-SPA-06	
		Semi-trailer	
SHEET	1	OF	1
REVISION	A		



GENERAL NOTES
 - 500MM VEHICLE BODY SHOWN WITH DASHED LINE
 - DESIGN VEHICLE SWEEP PATH COMPLETED AT 10KPH
 - ALL SWEEP PATHS COMPLETED ON SCALED AERIAL IMAGERY AND SHOULD BE VERIFIED ON SITE PRIOR TO HAULAGE OPERATIONS

UNWIN ST

SHIRLEY ST

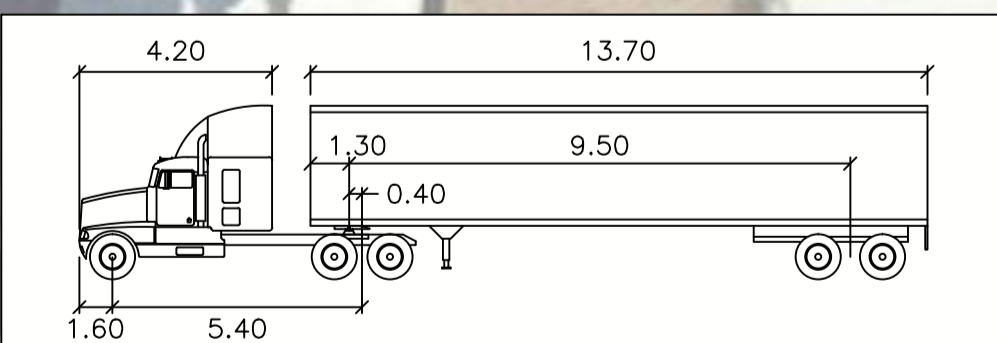

SEM1		meters	
Tractor Width	: 2.50	Lock to Lock Time	: 6.0
Tractor Track	: 2.50	Steering Angle	: 28.4
Tractor Wheelbase	: 5.40	Articulating Angle	: 70.0
Trailer Track	: 2.50		

DRAWN BY:	SS
DRW CHECK:	SL
APPROVED:	SL
IND REVIEW:	SL

PROJECT	
CLIENT	



CLYDE
SWEEP PATH ANALYSIS

DRAWING No: **CLY-SPA-07**
Semi trailer

SHEET	1	OF	1
REVISION	A		

REV	BY	DATE	DESCRIPTION	APPD.
A	SS	16/08/21	INITIAL DRAFT	SL

COORDINATE SYSTEM:	HEIGHT DATUM:	SCALE:
--------------------	---------------	--------



GENERAL NOTES
 - 500MM VEHICLE BODY SHOWN WITH DASHED LINE
 - DESIGN VEHICLE SWEEP PATH COMPLETED AT 10KPH
 - ALL SWEEP PATHS COMPLETED ON SCALED AERIAL IMAGERY AND SHOULD BE VARIFIED ON SITE PRIOR TO HAULAGE OPERATIONS

A

A

B

B

C

C

D

D

E

E

F

F

G

G

UNWIN ST

SHIRLEY ST

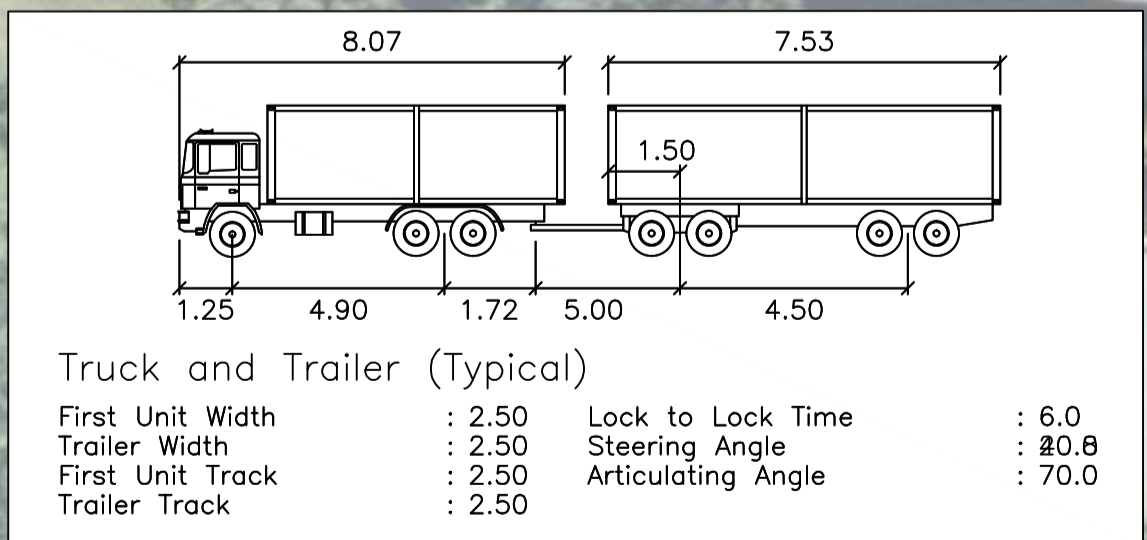
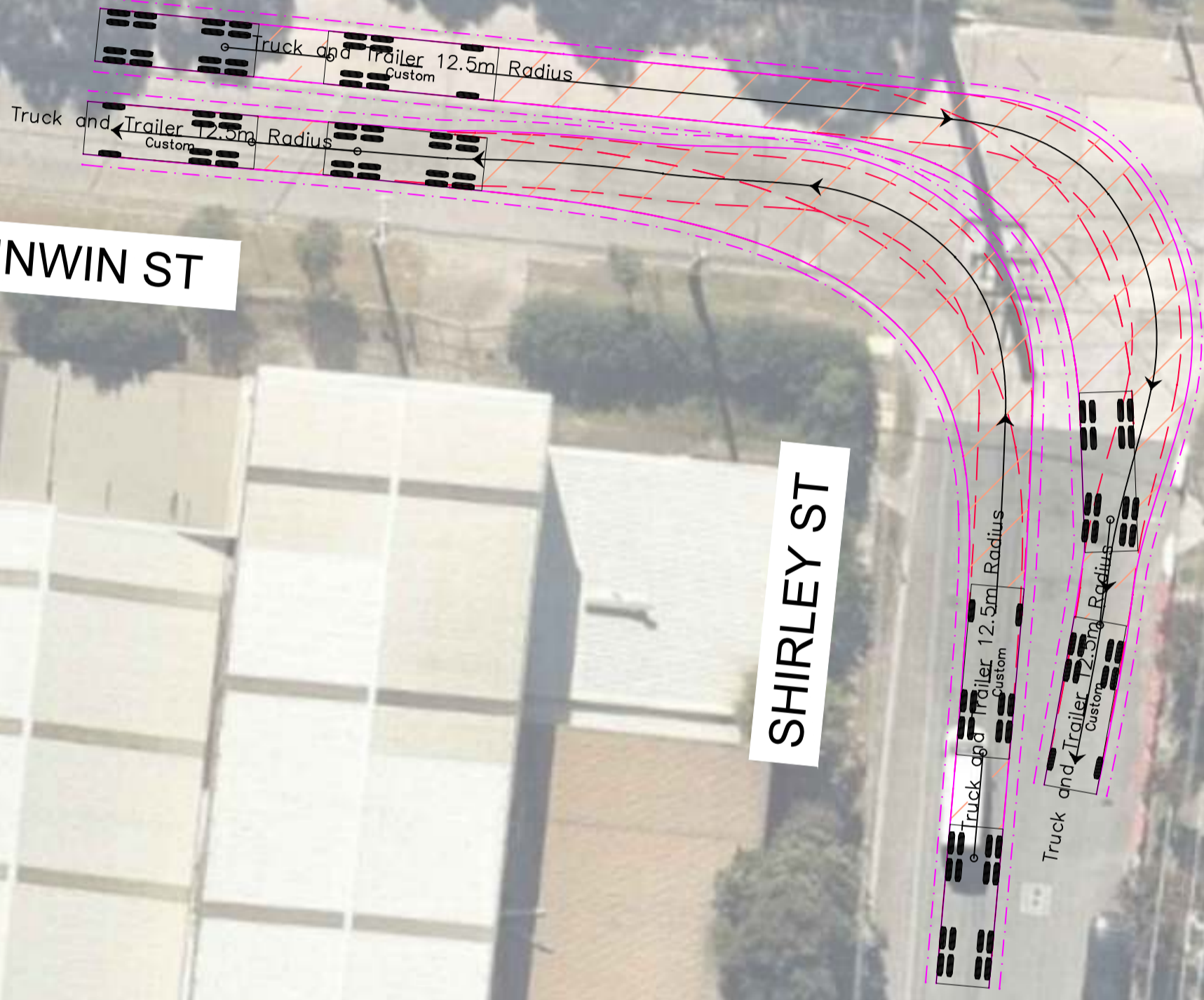

H

H

DRAWN BY:	SS
DRW CHECK:	SL
APPROVED:	SL
IND REVIEW:	SL

PROJECT	
CLIENT	



CLYDE
SWEEP PATH ANALYSIS

DRAWING No:	CLY-SPA-07		
	Truck and dog		
SHEET	1	OF	1
REVISION	A		

B : WRITTEN CONFIRMATION



30 March 2022

Sue Lewis
Director
Sue Lewis Consulting
on behalf of Gamuda Australia and
Laing O'Rourke Consortium (GLC)

Dear Sue,

Subject: Independent Review of Heavy Vehicle Local Road Report – Sydney Metro West, Western Tunnelling Package

I refer to your request for an assessment of the Heavy Vehicle Local Road Report (Document Ref. No.:SMWSTWTP-GLO-CLJ-HS-RPT-000001-B.01) and to provide comment in relation to the appropriateness and the 'fit for purpose' of the processes/measures proposed in the report.

I am writing to outline my advice in relation to the local road use associated with truck routes access/egress proposed for the Clyde/Rosehill sites as part of the Sydney Metro West – Western Tunnelling Package. I am a Certified Practising Engineer (Engineers Australia), NER and RPEQ with over 36 years' experience in traffic engineering, road design, risk management, crash investigation and road safety auditing. I am currently accredited as a senior road safety auditor in Victoria, South Australia, Queensland and Tasmania and a Level 3 Road Safety Auditor in NSW.

I have reviewed the document titled Heavy Vehicle Local Road Report (Document Ref. No.:SMWSTWTP-GLO-CLJ-HS-RPT-000001-B.01) supplied. The Ministerial Condition of Approval (MCoA D87) specifically requires:

- Truck Swept Path Analysis;
- Demonstration that the use of the local roads will not compromise the safety of pedestrians and cyclists or traffic flow;
- Road dilapidation requirements;
- Measures to avoid local road use where practical and to avoid schools, aged care facilities and child care facilities during peak operational times.

The proposed routes into the site for the works are via Wentworth Street, Kay Street, Unwin Street, Shirley Street, Martha Street, Deniehy Street and Tennyson Street.

The swept path analysis supplied indicates that all semi-trailer and truck & dog turning movements can be adequately accommodated at all intersections that form part of the proposed heavy vehicle route other than at the following intersections:

- Unwin Street onto Shirley Street;
- Martha Street onto Wentworth Street.

Semi-trailer movements at the above two intersections will not be permitted and drivers will be instructed accordingly during training and induction.

I note that the abutting development along the proposed route is essentially industrial and would therefore already have trucks using the subject roads. The project area and the closed



businesses in the area would result in a reduction in pedestrian activity. It is understood that warning signs had been installed previously where Wentworth Street crosses Martha Street in the vicinity of M4 Motorway shared path cycleway. I note that additional warning signs and decals are proposed to be installed on Martha Street and Deniehy Street.

Given the proposed project area and the prevailing environment being industrial with no aged care or child care facilities or schools being present, the use of the proposed local roads is expected to have limited to no adverse impact on pedestrians and/or sensitive facilities. The proposed heavy vehicle route report appears to meet the requirements outlined in MCoA D87.

Sincerely,

A handwritten signature in blue ink, appearing to read 'Raj Muthusamy', written in a cursive style.

Raj Muthusamy
Director / Level 3 Road Safety Auditor
Road Safety Audits

C : STAKEHOLDER CONSULTATION

DOCUMENT NO.	TITLE	VER	STATUS	NO.	DATE	COMPANY	RAISED BY	REVIEW DOC. NO.*	DOCUMENT REF*	DEED REF*	COMMENTS / RESPONSE	COMMENT CATEGORY*	CLOSED OUT
SMWSTWTP-GLO-CLJ-HS-RPT-000001	Sydney Metro West - WTP - Heavy Vehicle Local Road Report - Clyde/ Rosehill	02.01	S3	01	26/04/2022	SMD	PBROGAN	SMWSTWTP-GLO-CLJ-HS-RPT-000001-B.01	general	tba	DPIE - Change to DPE - (Department of Planning and Environment).	Observation	Y
								SMWSTWTP-GLO-CLJ-HS-RPT-000001-B.01	general	tba		Observation	Y
				01.01	17/05/2022	GLO	SBESIM	SMWSTWTP-GLO-CLJ-HS-RPT-000001-B.01	general	tba	Document amended	Observation	Y
								SMWSTWTP-GLO-CLJ-HS-RPT-000001-B.01	general	tba		Observation	Y
				02	26/04/2022	SMD	PBROGAN	SMWSTWTP-GLO-CLJ-HS-RPT-000001-B.01	Section 2.1	tba	Section 2.1 - Acknowledge CTMF and relevant provisions. Also Section 4.	Observation	Y
								SMWSTWTP-GLO-CLJ-HS-RPT-000001-B.01	Section 2.1	tba		Observation	Y
				02.01	17/05/2022	GLO	SBESIM	SMWSTWTP-GLO-CLJ-HS-RPT-000001-B.01	Section 2.1	tba	Document amended	Observation	Y
								SMWSTWTP-GLO-CLJ-HS-RPT-000001-B.01	Section 2.1	tba		Observation	Y
				03	26/04/2022	SMD	PBROGAN	SMWSTWTP-GLO-CLJ-HS-RPT-000001-B.01	Section 7	tba	Trucks to be used should also have regard to the CTMF and the vehicle types specified in Section 10.3.2 of the Stage 1 EIS.	Observation	Y
								SMWSTWTP-GLO-CLJ-HS-RPT-000001-B.01	Section 7	tba		Observation	Y
				03.01	17/05/2022	GLO	SBESIM	SMWSTWTP-GLO-CLJ-HS-RPT-000001-B.01	Section 7	tba	Document amended	Observation	Y
								SMWSTWTP-GLO-CLJ-HS-RPT-000001-B.01	Section 7	tba		Observation	Y
				04	26/04/2022	SMD	PBROGAN	SMWSTWTP-GLO-CLJ-HS-RPT-000001-B.01	Table 6	tba	Table 6 - Are large heavy rigid trucks proposed to be used as provided for in the Stage 1 EIS ? If so, their swept paths would need to be checked. What is the likelihood of a Metro contractor semi trailer or heavy rigid truck coinciding with a PBS vehicle at one or more of these intersection / turn locations and what mitigations will be put in place for this ?	Observation	Y
								SMWSTWTP-GLO-CLJ-HS-RPT-000001-B.01	Table 6	tba		Observation	Y
				04.01	17/05/2022	GLO	SBESIM	SMWSTWTP-GLO-CLJ-HS-RPT-000001-B.01	Table 6	tba	The swept paths are provided in Appendix A. Concurrent swept paths are shown at all locations. All swept paths are suitable other than as noted in the report	Observation	Y
								SMWSTWTP-GLO-CLJ-HS-RPT-000001-B.01	Table 6	tba		Observation	Y
				05	27/04/2022	TFN	LWILBY	SMWSTWTP-GLO-CLJ-HS-RPT-000001	Appendix A Swept Path Analysis - CLY-SPA-03	NA	The swept path for semi trailer movements between Deniehy St and Tennyson St show significant encroachment into the oncoming traffic lane on a tight bend. Please confirm how these movements will be managed to reduce the risk of collision with other heavy vehicles or road users.	Observation	Y
								SMWSTWTP-GLO-CLJ-HS-RPT-000001	Appendix A Swept Path Analysis - CLY-SPA-03	NA		Observation	Y
				05.01	17/05/2022	GLO	SBESIM	SMWSTWTP-GLO-CLJ-HS-RPT-000001	Appendix A Swept Path Analysis - CLY-SPA-03	NA	This area will form part of the site and not open to the public. All businesses have been relocated from this area with only GLC having access	Observation	Y
								SMWSTWTP-GLO-CLJ-HS-RPT-000001	Appendix A Swept Path Analysis - CLY-SPA-03	NA		Observation	Y
				05.01.01	20/05/2022	TFN	LWILBY	SMWSTWTP-GLO-CLJ-HS-RPT-000001	Appendix A - Swept Path Analysis	NA	Comment noted that this intersection will form part of the site. Still consider mitigation such as straightening up intersection to improve swept path, signage and so on. Otherwise comment is closed.	Observation	Y

DOCUMENT NO.	TITLE	VER	STATUS	NO.	DATE	COMPANY	RAISED BY	REVIEW DOC. NO.*	DOCUMENT REF*	DEED REF*	COMMENTS / RESPONSE	COMMENT CATEGORY*	CLOSED OUT
								SMWSTWTP-GLO-CLJ-HS-RPT-000001	Appendix A - Swept Path Analysis	NA		Observation	Y
				08	3/05/2022	SMD	AHENDY	SMWSTWTP-GLO-CLJ-HS-RPT-000001-B.01	Table 1	Schedule D4	Table 1, page 10 - document reference for Condition of Approval D87(c) is given as Appendix C. Suggest this should be Appendix D, as Appendix C is for Stakeholder Consultation. Appendix D is also blank - this will need to be updated prior to submission to DPE for review and approval.	Potential Non-Compliance	N
								SMWSTWTP-GLO-CLJ-HS-RPT-000001-B.01	Table 1	Schedule D4		Potential Non-Compliance	N
				08.01	17/05/2022	GLO	SBESIM	SMWSTWTP-GLO-CLJ-HS-RPT-000001-B.01	Table 1	Schedule D4	Document amended	Potential Non-Compliance	N
								SMWSTWTP-GLO-CLJ-HS-RPT-000001-B.01	Table 1	Schedule D4		Potential Non-Compliance	N
				08.01.01	25/05/2022	SMD	AHENDY	SMWSTWTP-GLO-CLJ-HS-RPT-000001	Appendix D	Schedule D4	Reference changed to Appendix D as suggested, however Appendix D remains blank. As per original comment, this needs to be updated to include details as to the date of completion of the road dilapidation surveys for the subject local roads prior to submission to DPE - without this information they will send it straight back.	Potential Non-Compliance	N
							SBESIM	SMWSTWTP-GLO-CLJ-HS-RPT-000001	Appendix D	Schedule D4	Appendix now included	Potential Non-Compliance	N
				09	3/05/2022	SMD	AHENDY	SMWSTWTP-GLO-CLJ-HS-RPT-000001-B.01	Table 1	NA	Table 1, page 10 - minor typo in wording for Condition of Approval D87(d). "sue" instead of "use". Currently states: "Measures that will be implemented to avoid where practicable the sue of local roads past schools ..."	Observation	Y
								SMWSTWTP-GLO-CLJ-HS-RPT-000001-B.01	Table 1	NA		Observation	Y
				09.01	17/05/2022	GLO	SBESIM	SMWSTWTP-GLO-CLJ-HS-RPT-000001-B.01	Table 1	NA	Document amended	Observation	Y
								SMWSTWTP-GLO-CLJ-HS-RPT-000001-B.01	Table 1	NA		Observation	Y
				10	3/05/2022	SMD	AHENDY	SMWSTWTP-GLO-CLJ-HS-RPT-000001-B.01	Table 1	NA	Table 1, page 10 - Condition of Approval D87(c) requires: "measures that will be implemented to avoid where practicable the use of local roads past schools, aged care facilities and child care facilities during their peak operation times; and" This HVLr is for Clyde / Rosehill yet section 7 states "Construction traffic will be managed to minimise movements during peak periods and through school zones during drop off and pick up times, in particular at the Westmead and Parramatta sites and this will be achieved through scheduling of vehicles and staggered start and finish times." Suggest removing statement as is not relevant to Clyde / Rosehill area. The only information in response to use of local roads past schools, aged care facilities and child care facilities during their peak operation times is included in the written advice from from a qualified professional in Appendix B. "Given the proposed project area and the prevailing environment being industrial with no aged care or child care facilities or schoo 郵y `郵y 漫鋤y 耀@	Observation	Y
								SMWSTWTP-GLO-CLJ-HS-RPT-000001-B.01	Table 1	NA		Observation	Y
				10.01	25/05/2022	SMD	AHENDY	SMWSTWTP-GLO-CLJ-HS-RPT-000001	Section 7	NA	Reference to Westmead and Parramatta remains in Section 7, but not critical. Comment to be closed.	Observation	Y
								SMWSTWTP-GLO-CLJ-HS-RPT-000001	Section 7	NA		Observation	Y

DOCUMENT NO.	TITLE	VER	STATUS	NO.	DATE	COMPANY	RAISED BY	REVIEW DOC. NO.*	DOCUMENT REF*	DEED REF*	COMMENTS / RESPONSE	COMMENT CATEGORY*	CLOSED OUT
				11	3/05/2022	SMD	AHENDY	SMWSTWTP-GLO-CLJ-HS-RPT-000001-B.01	Table 1	NA	Table 1, page 10 - document reference for Condition of Approval D88 is given as Section 7.1. Suggest also providing reference to Appendix D and ensuring Appendix D is updated to include content prior to next submission.	Observation	N
								SMWSTWTP-GLO-CLJ-HS-RPT-000001-B.01	Table 1	NA		Observation	N
				11.01	17/05/2022	GLO	SBESIM	SMWSTWTP-GLO-CLJ-HS-RPT-000001-B.01	Table 1	NA	Document amended	Observation	N
								SMWSTWTP-GLO-CLJ-HS-RPT-000001-B.01	Table 1	NA		Observation	N
				11.01.01	25/05/2022	SMD	AHENDY	SMWSTWTP-GLO-CLJ-HS-RPT-000001	Appendix D	Schedule D4	Reference updated to include Appendix D as suggested, however Appendix D remains blank. As per original comment, this needs to be updated to include details as to the date of completion of the road dilapidation surveys for the subject local roads prior to submission to DPE - without this information they will send it straight back.	Observation	N
							SBESIM	SMWSTWTP-GLO-CLJ-HS-RPT-000001	Appendix D	Schedule D4	Appendix now included	Observation	N
				12	3/05/2022	SMD	AHENDY	SMWSTWTP-GLO-CLJ-HS-RPT-000001-B.01	General	NA	General comment - check and update references throughout document. Several references to different sections or Figures are incorrect.	Observation	Y
								SMWSTWTP-GLO-CLJ-HS-RPT-000001-B.01	General	NA		Observation	Y
				12.01	17/05/2022	GLO	SBESIM	SMWSTWTP-GLO-CLJ-HS-RPT-000001-B.01	General	NA	Document amended	Observation	Y
								SMWSTWTP-GLO-CLJ-HS-RPT-000001-B.01	General	NA		Observation	Y
				13	19/05/2022	SMD	PBROGAN				No Comments		Y
											Noted		Y
				14	23/05/2022	SMD	BGORDON				No Comments		Y
											Noted		Y

D : ROAD DILAPIDATION REPORT TRANSMITTAL

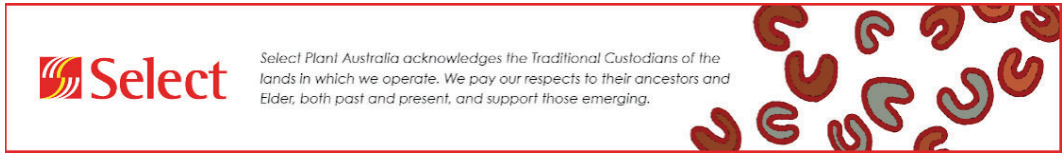

From: Sam Besim via InEight Document <system@teambinder.com>
Sent: Monday, 11 April 2022 5:58 PM
To: Kelly, Daniel ·
Subject: Sydney Metro West - WTP - Clyde Dilapidation Survey - Issued for Information



Document Transmittal

Transmittal No:	SMWSTWTP-GLO-TX-000082
Contract No:	WTP - 00013/13065 - Western Tunnelling Works Design and Construction Deed
Sub Contract:	
Date:	11 April 2022, 05:58 PM

Issued	Name
By	Sam Besim (Gamuda Laing O'Rourke Consortium)

Issued	Name
To	Tania Page (Sydney Metro) ; Andrew Hendy (Sydney Metro)
Cc	Denniel Custodio (Sydney Metro) ; Demi Tascas (Sydney Metro) ; David Kong (Gamuda Laing O'Rourke)

Consortium); Matthew Marrinan (Sydney Metro); Sarah Lepre (Sydney Metro); Daniel Kelly (Gamuda Laing O'Rourke Consortium); Simon Hussey (Gamuda Laing O'Rourke Consortium); Andy Thompson (Gamuda Laing O'Rourke Consortium); Liem Ngo (Gamuda Laing O'Rourke Consortium); Hayley Young (Gamuda Laing O'Rourke Consortium); Niall Fry (Gamuda Laing O'Rourke Consortium); Richard Searle (Parramatta City Council); Steph Mifsud (Gamuda Laing O'Rourke Consortium)

Reason for Issue	Issued for Information
Subject	Sydney Metro West - WTP - Clyde Dilapidation Survey - Issued for Information
<p>Dear Sydney Metro</p> <p>Please find attached Road Dilapidation report undertaken for the Clyde area. This dilapidation survey was undertaken in advance of works proposed at the Rosehill and Clyde MSF sites.</p> <p>GLC requests Sydney Metro issue the results of the Rod Dilapidation survey to Parramatta City Council in accordance with Condition of Approval D88.</p> <p>Kind Regards, Sam Besim, Document Controller Gamuda Engineering (Australia) Pty Ltd</p> <p>A Suite 26.01, 100 Miller Street, North Sydney, NSW 2060</p>	

[Click here to download all Transmittal files.](#)

Item	Document No	Title	Rev	Sts	Type	Design Lots	Alt Doc No
1	SMWSTWTP-GLO-CLJ-EN-SUR-000001	Sydney Metro West - WTP - Clyde Dilapidation Survey	-.01	S2	SUR		